

Procesamiento de Imágenes y Bioseñales

Dr. Víctor Castañeda

- Physical basis of X-ray- CT, NMR, Ultrasound, Nuclear Medicine
- Sensors (cameras, gamma probes, microphone)
- Computational Tomography (CT)
- Magnetic Resonance Imaging (MRI)
- Positron Emission Tomography (PET)
- Single-photon emission computed tomography (SPECT)
- Ultrasound

- Metal, Semiconductor, Insulator

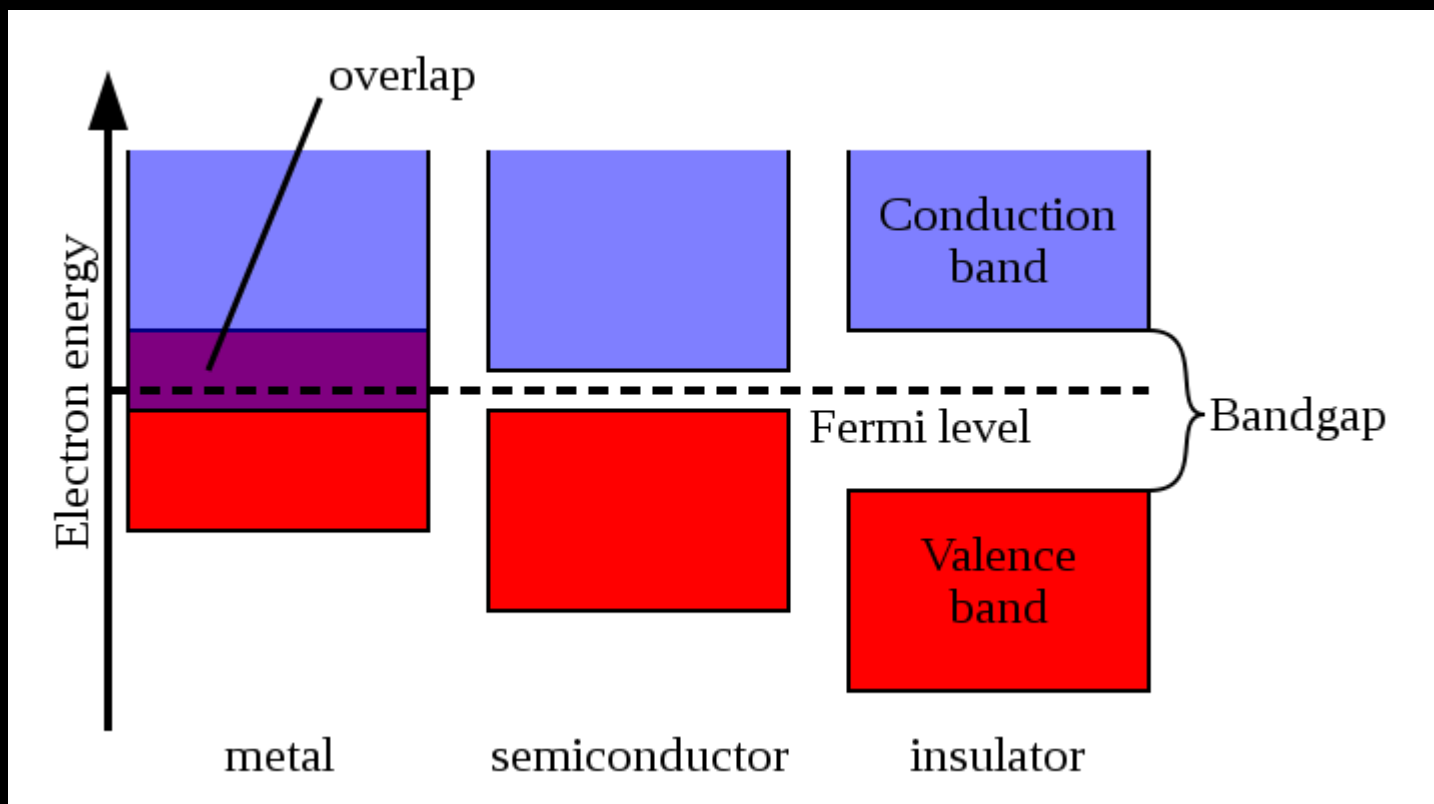

- 1D Sensor

- Piezoelectric

- Measure mechanical motion
 - Generate a voltage when deformed
 - mechanical stress causes the charge separation in the individual atoms of the material
 - Eg. Audio, autofocus objective

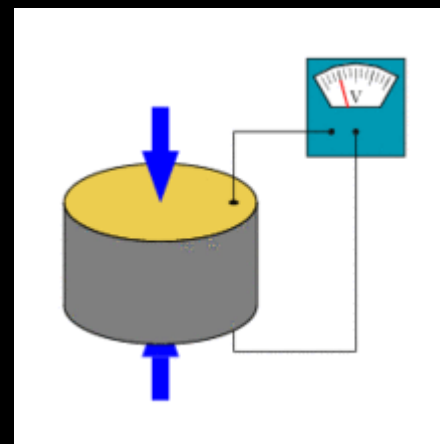

Principle	Strain Sensitivity [V/ μ^*]	Threshold [μ^*]	Span to threshold ratio
Piezoelectric	5.0	0.00001	100,000,000
Piezoresistive	0.0001	0.0001	2,500,000
Inductive	0.001	0.0005	2,000,000
Capacitive	0.005	0.0001	750,000

- 1D sensor
 - Photomultiplier
 - Detect photons and amplify the signal (by 100 million times)
 - Sum signal of all detected photons
 - Very sensitive

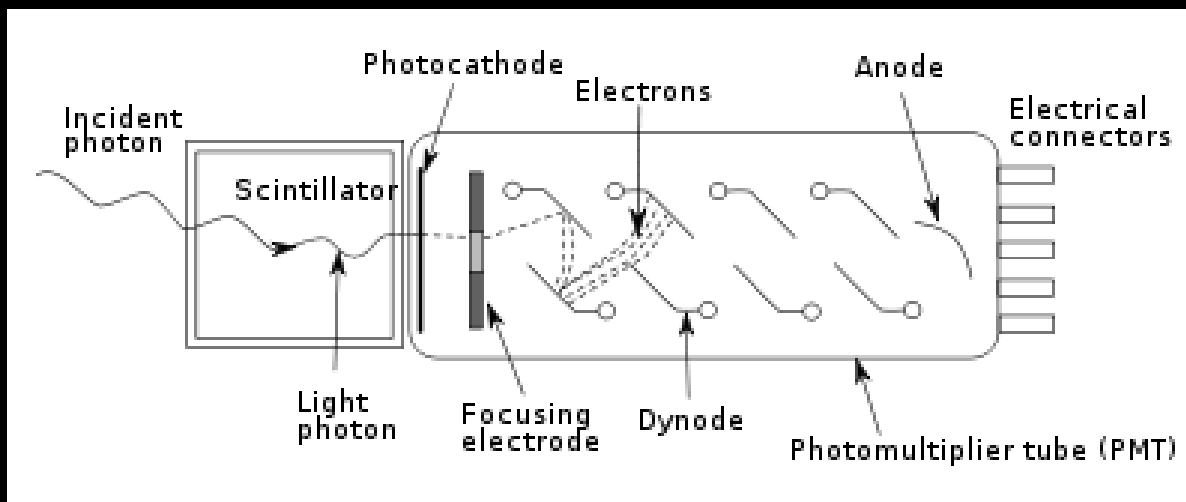

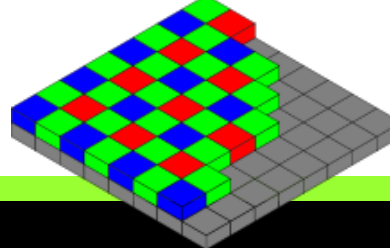

- 2D-Sensor

- charge-coupled device (CCD)

- Low noise
- High power consumption
- Need move charges

- Complementary metal-oxide-semiconductor (CMOS)

- Moderate noise
- Low power consumption
- Region Of Interest
- Read directly from pixel storage

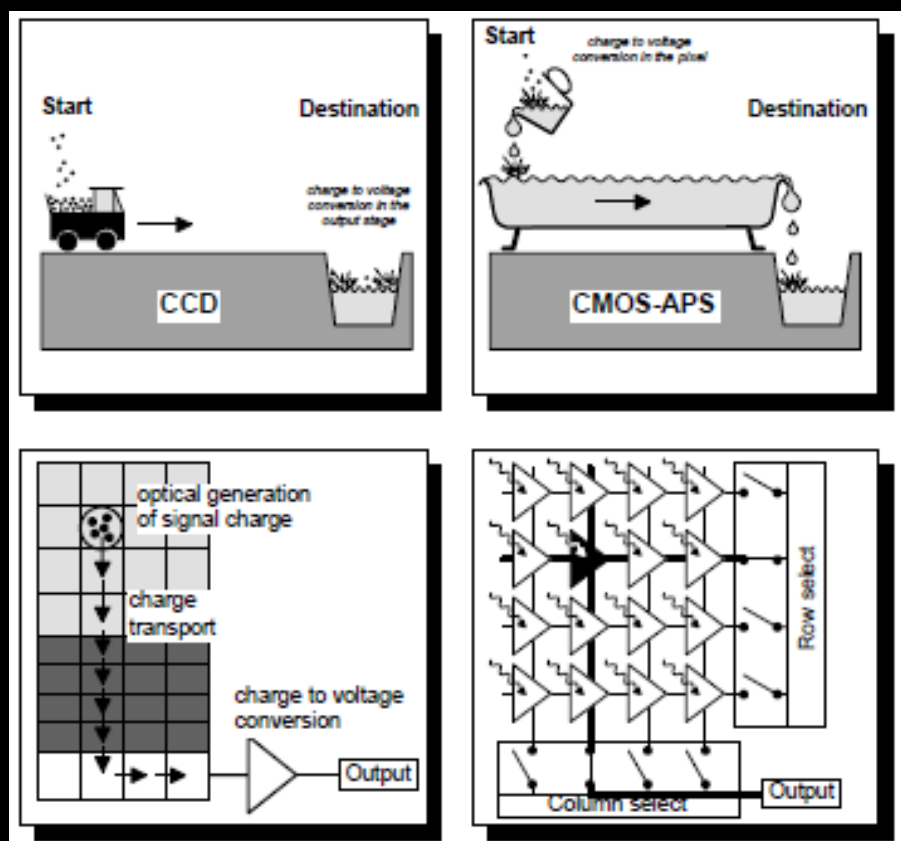
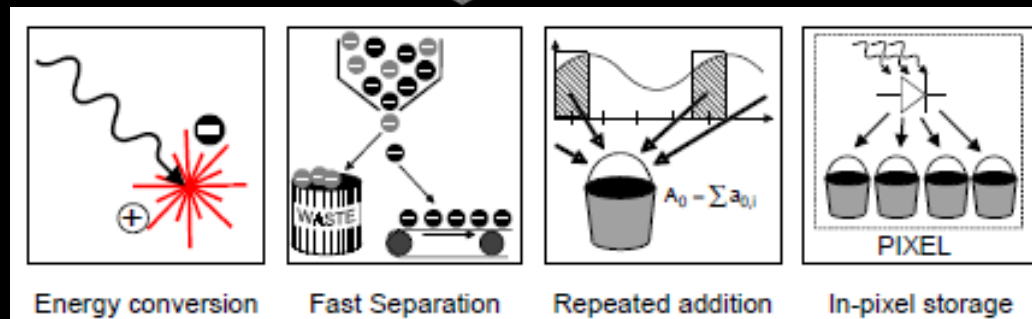

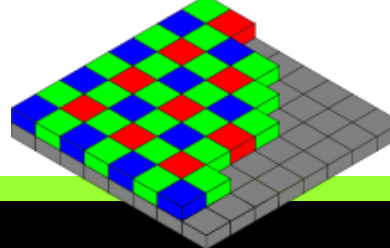

- 2D-Sensor

- Electron multiplying charge-coupled device (EMCCD)

- Very low noise
- High and broad QE
- Single Photon Sensitive
- Good dynamic range possible
- Fast or slow readout

- Scientific complementary metal–oxide–semiconductor (sCMOS)

- Extremely low noise
- Rapid frame rates
- Wide dynamic range
- High quantum efficiency (QE)

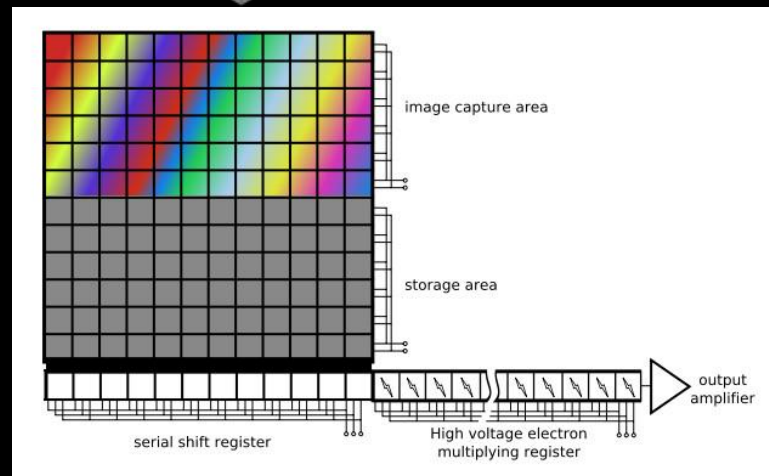

Solid state Electron Multiplying (EM) register to the end of the normal serial register

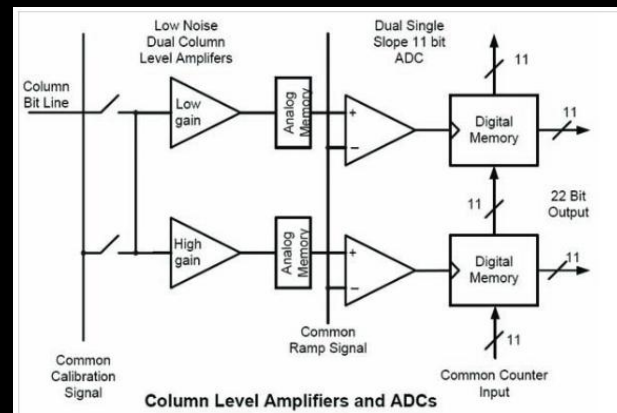

It is a mix between CCD/CMOS

The hand of Mrs. Wilhelm
Roentgen: the first X-ray image,
1895

*In Otto Glasser, Wilhelm Conrad
Röntgen and the early history of
the Roentgen rays. London, 1933.
National Library of Medicine.*

The announcement of Roentgen's
discovery, illustrated with an X-ray
photograph of his wife's hand, was hailed
as one of mankind's greatest technological
accomplishments, an invention that would
revolutionize every aspect of human
existence.

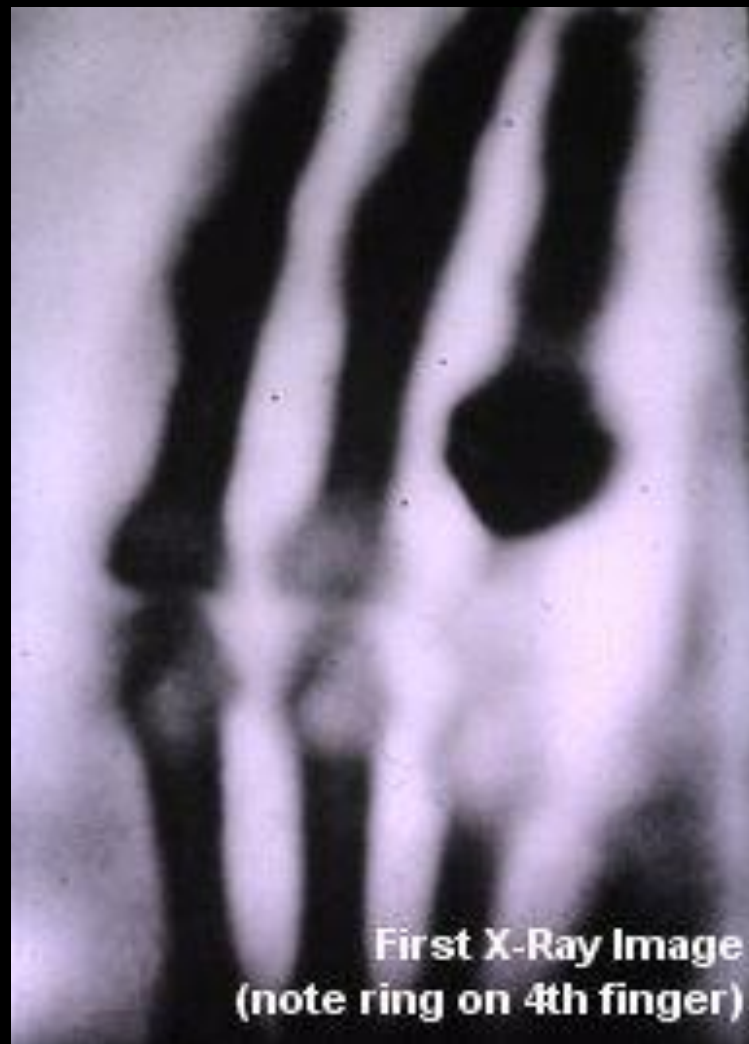

- Take a picture of inside body
- It emits a gamma ray
- The attenuation of the rays is the basis of working



- Photons with energies 50-120 keV are emitted by an X-Ray source
- Interaction with biological tissue absorbs & scatters some of the photons (photo-electric and Compton effect)

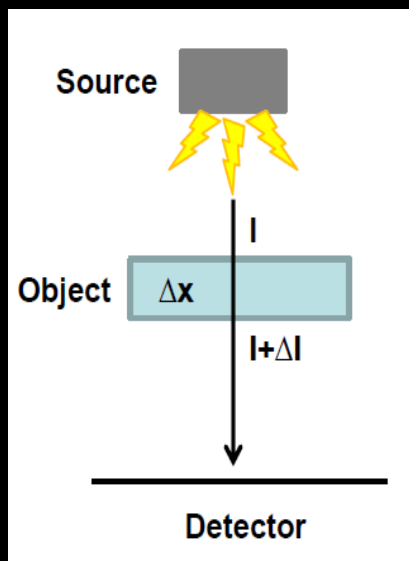

» Attenuation through homogenous

» medium Infinitesimally

» small object Integration yields

» Resulting in

» or

$$\frac{\Delta I}{I} \frac{1}{\Delta x} = -\mu$$

$$\frac{1}{I} dI = -\mu dx$$

$$\int_{I_0}^I \frac{dI}{I} = -\mu \int_0^x dx$$

$$\ln I - \ln I_0 = -\mu x$$

$$I(x) = I_0 e^{-\mu x}$$

Beer-Lambert Law

- Attenuation through inhomogeneous medium

$$I_d = I_0 \exp \left(- \int_{\vec{x} \in l} \mu(\vec{x}) ds \right)$$

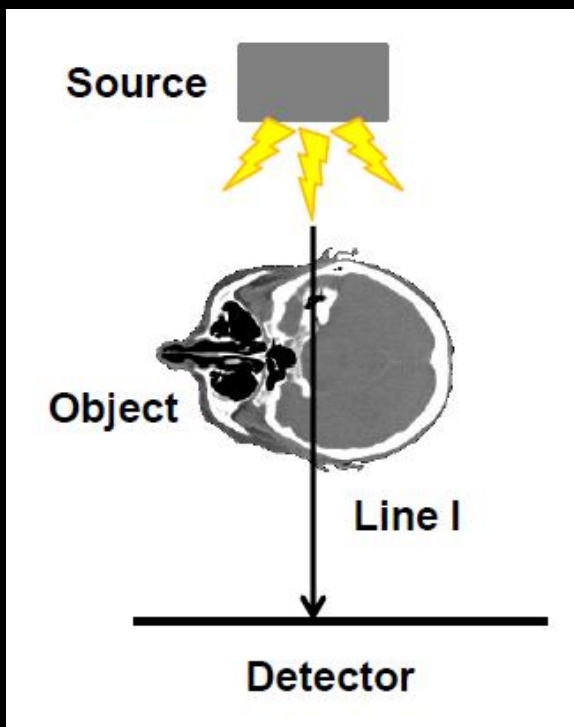

Detector Intensity \longrightarrow

$$\int_{\vec{x} \in l} \mu(\vec{x}) ds = \ln \frac{I_0}{I_d}$$

Attenuation Integral \longrightarrow

We are considering linear attenuation coefficients μ



Hounsfield Units

- Named after the inventor of CT, normalized reconstruction intensities where air=-1000 and water=0 → considered during scanner calibration

$$HU = \frac{\mu - \mu_{Water}}{\mu_{Water}} \cdot 1000$$

- Typical X-Ray data has 12 bit precision [-1000, 3095]

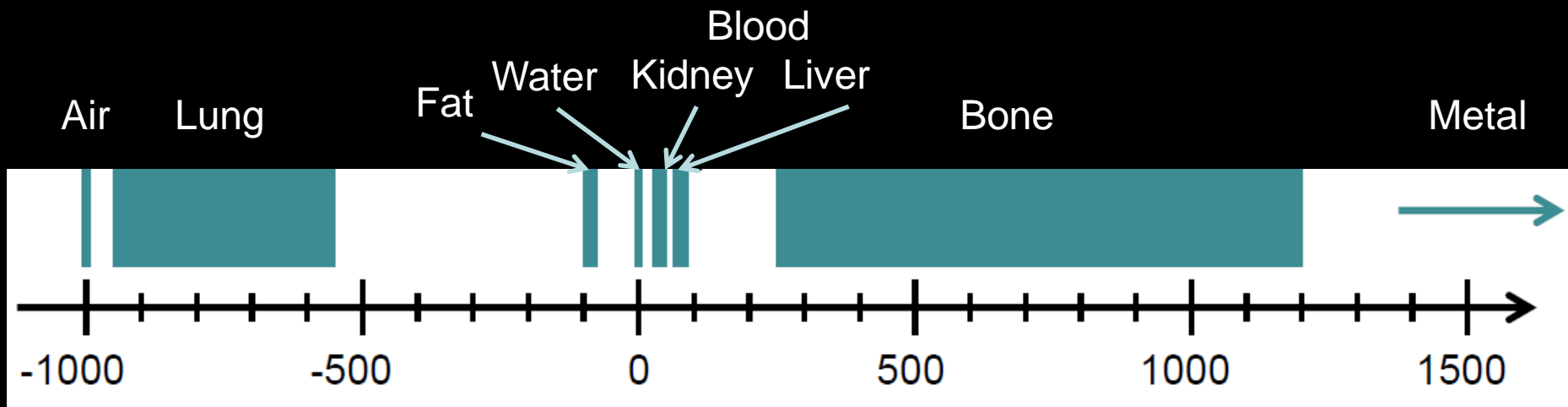

- CT Principles

- X-Ray of different orientation -> Computed Tomography (CT)
- Geometric Principles:

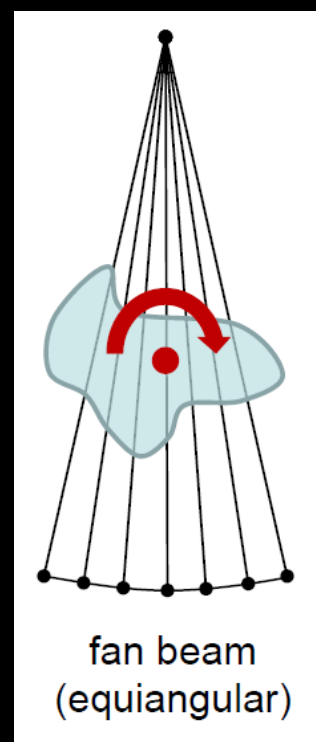
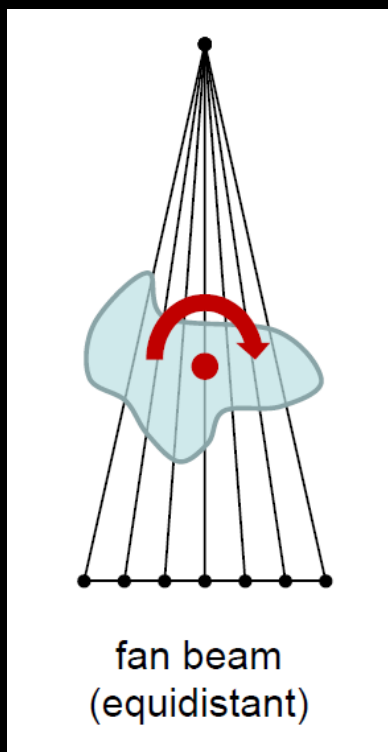
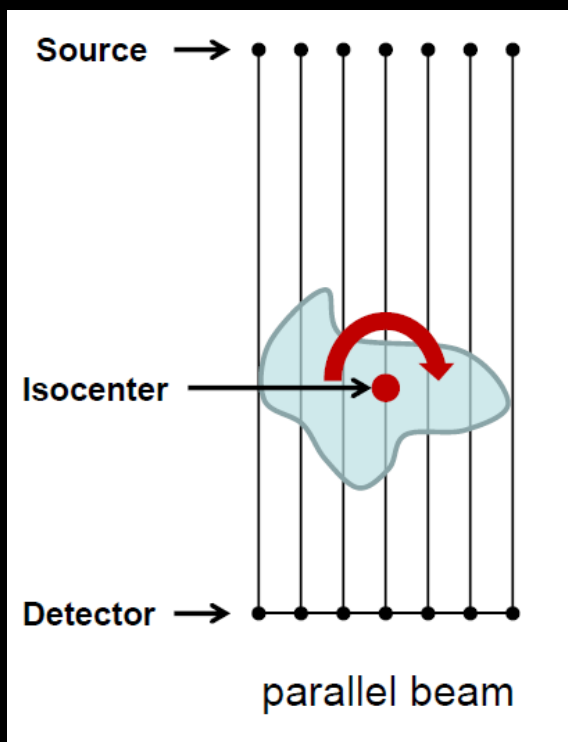

- **The Radon Transform in 2D**

- Integral of a 2D function $f : \mathbb{R}^2 \rightarrow \mathbb{R}$ over straight lines

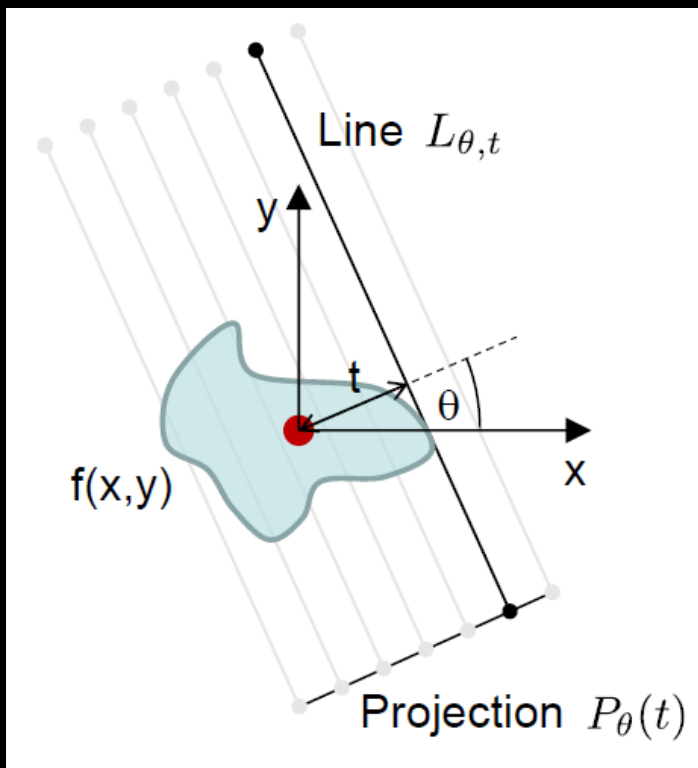

$$P_{\theta}(t) = (R \circ f)(\theta, t) = \int_{L_{\theta,t}} f(\vec{x}) ds$$

Dirac delta function over line equation:

$$P_{\theta}(t) = \int_{-\infty}^{\infty} \int_{-\infty}^{\infty} f(x, y) \delta(x \cos \theta + y \sin \theta - t) dx dy$$

As a parameterized line:

$$P_{\theta}(t) = \int_{-\infty}^{\infty} f(\lambda \sin \theta + t \cos \theta, -\lambda \cos \theta + t \sin \theta) d\lambda$$

CT Example

- Original image and sinogram of the Shepp-Logan head phantom

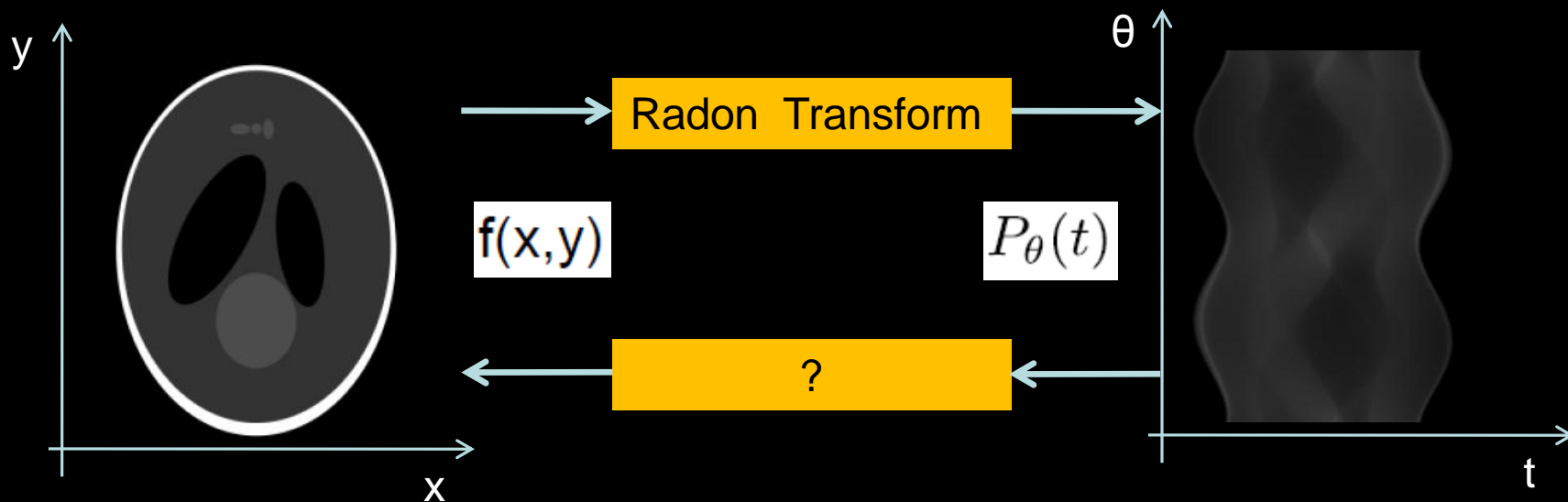

- We have the sinogram – how can we invert the Radon transform to yield the reconstructed image?



Projections



Filtered Projections

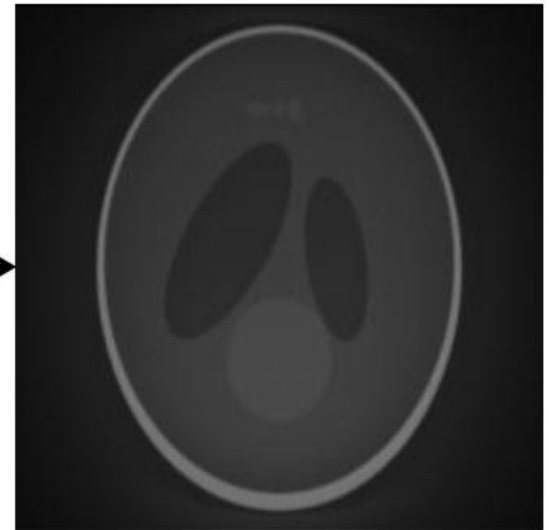

Backprojection

- **Effect of number of projections (fan-beam case)**

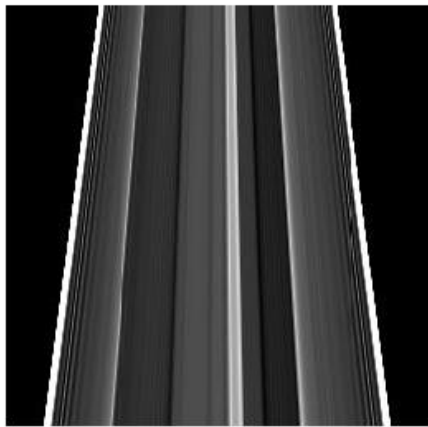

1

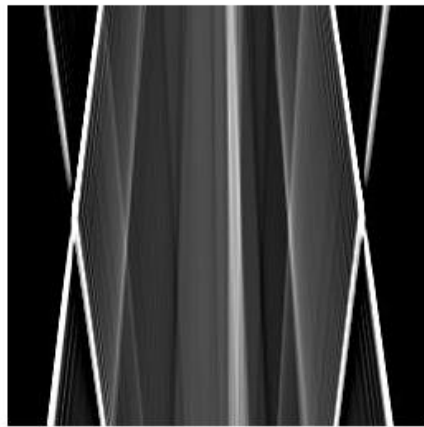

2

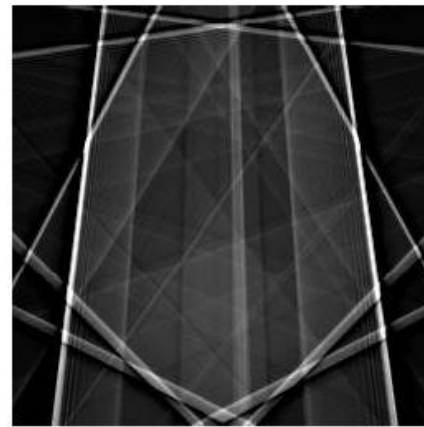

5

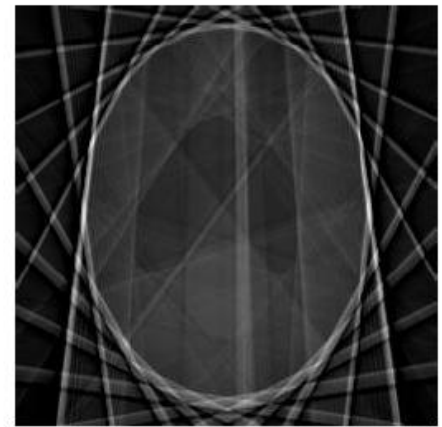

10

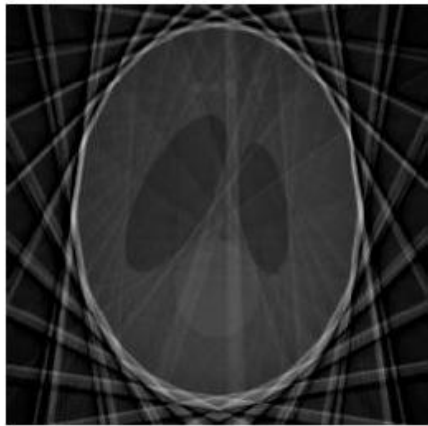

20

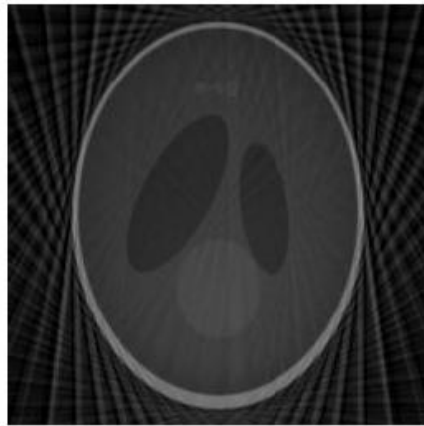

50

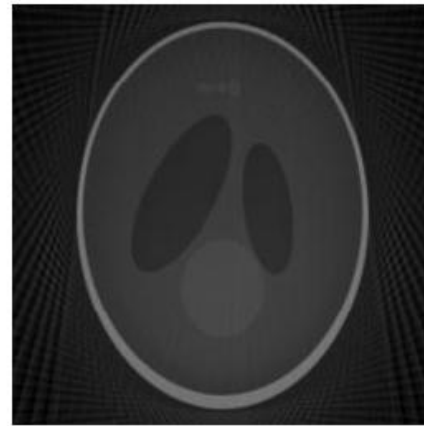

100

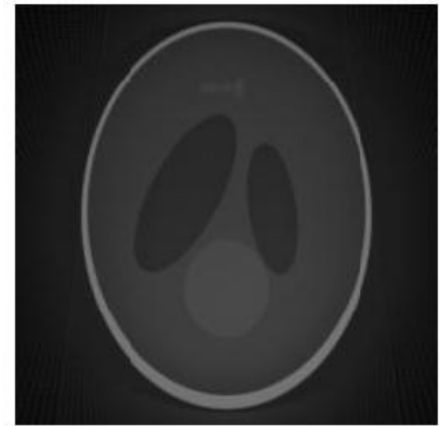

200

- Single-slice: ~1000 angles and detector bins, several revolutions per second
- Spiral CT geometry due to continuous table motion
 - z-Interpolation/Filtering to use 2D FBP for spiral CT reconstruction!
- Multi-slice scanners: up to 256 detector lines
 - Designated 3D reconstruction required!

Circular trajectory
required for FBP:

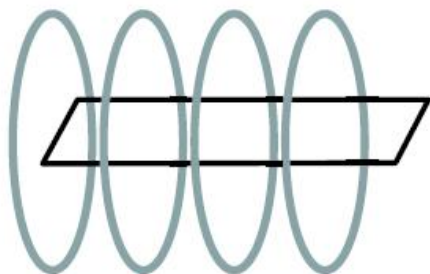

Actual spiral
CT trajectory:

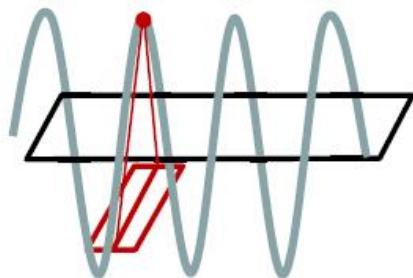

Courtesy of Siemens Healthcare

- 3D-Reconstruction Workflow

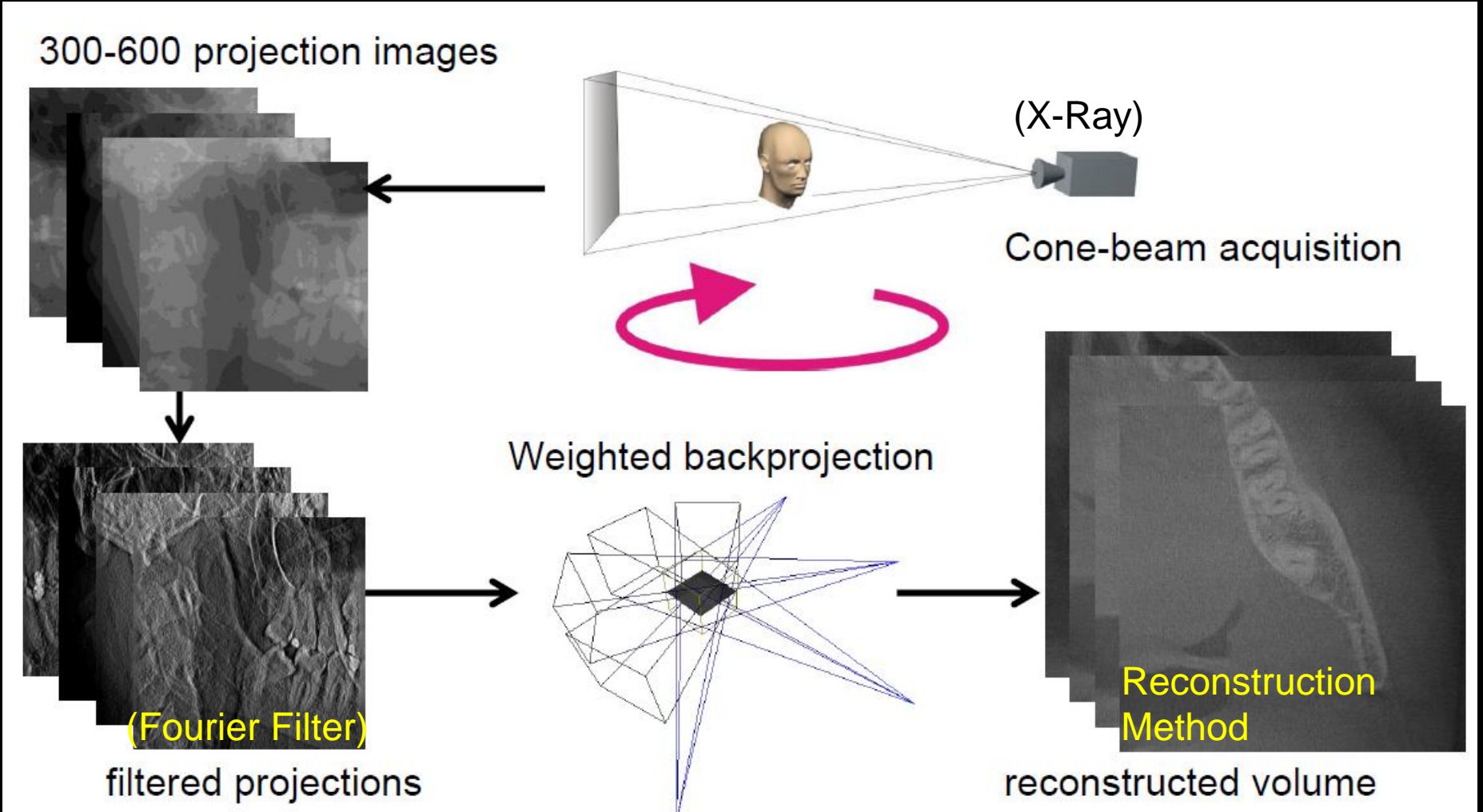

Nuclear Magnetic Resonance (NMR)

- Quantum physics tells us that an atomic nucleus has a magnetic moment. Its precession in a magnetic field with a (or Larmor) frequency ω is defined as the product of the external magnetic field strength B and the so called gyromagnetic ratio γ : $\omega = \gamma \cdot B$
- In nuclei with an uneven number of spins that remainder creates a magnetic moment.

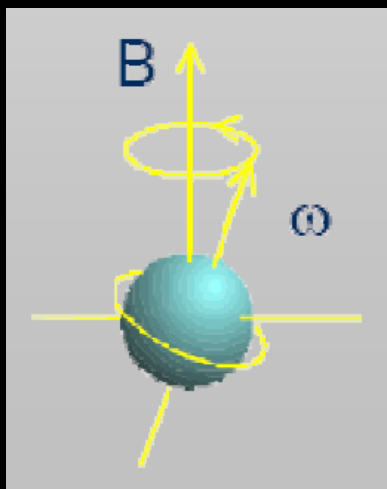

• Examples for γ :

1H	42.6	$\frac{MHz}{Tesla}$
^{13}C	10.8	$\frac{MHz}{Tesla}$
^{19}F	40.0	$\frac{Mhz}{Tesla}$
^{31}P	17.2	$\frac{MHz}{Tesla}$

- From the quantum mechanics point of view, only two states (parallel and anti parallel are possible for spins ; $m = \pm \frac{1}{2}$)

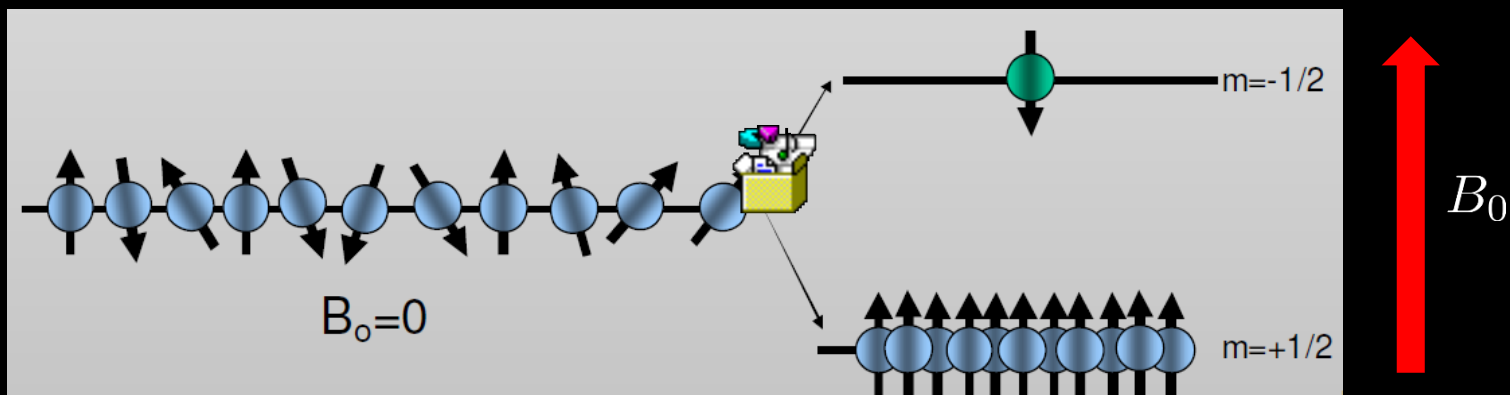

- The transition between the states requires or gains the B_0 energy $E = -\gamma \cdot h \cdot B$. The macroscopic distribution is governed by the Boltzmann statistics. Under typical conditions, the net excess is in the **ppm range** (1.5 T equals 3000x the earth's magnetic field)

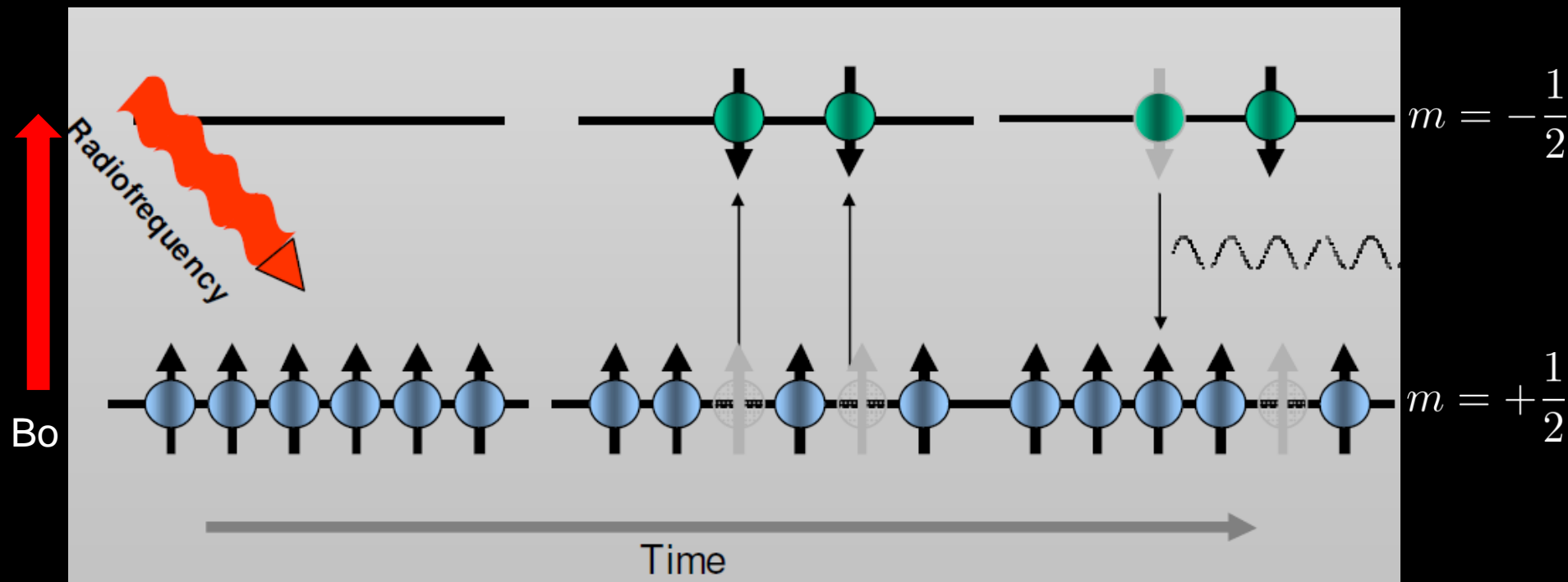

In summary, external RF brings some spins into the anti-parallel state - which is left after a few moments under emission of a quant
 This quant is emitted in **any** direction – but can be detected by an antenna !

We normally capture only water signal

https://www.youtube.com/watch?v=djAxjtN_7VE

- Spin-Echo-Sequence (SE)

90°

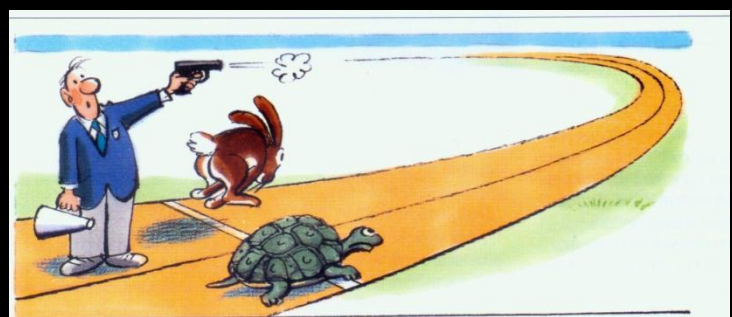

180°



Spin-Echo

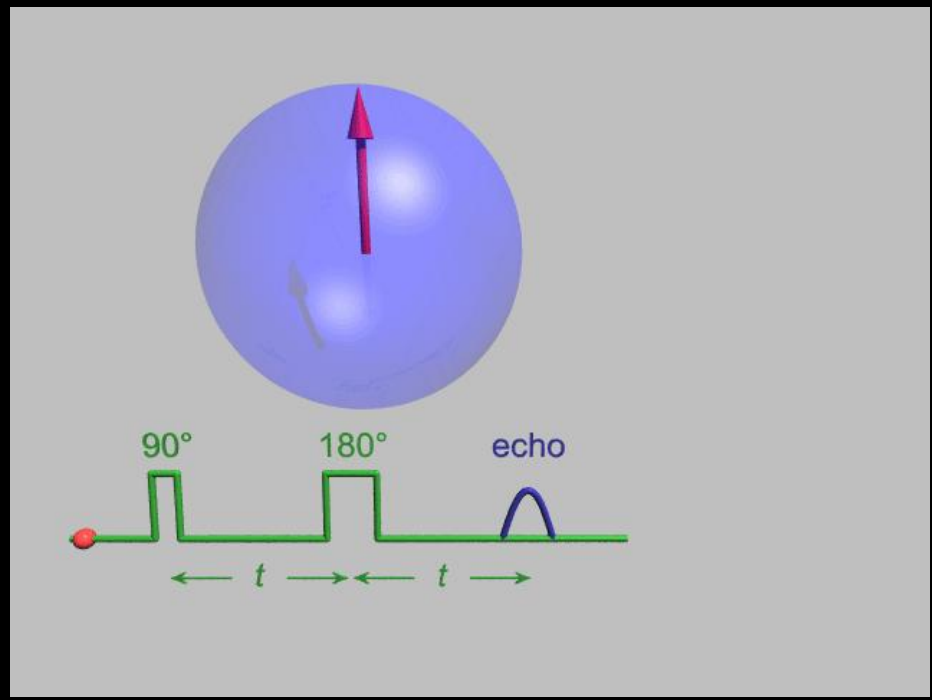
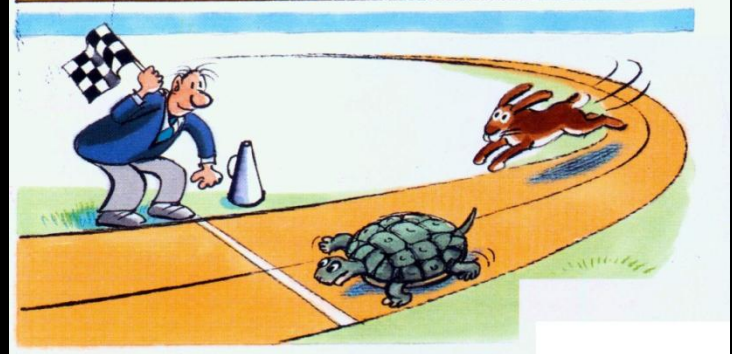

- Relaxation

- This relaxation process can be separated in two factors: longitudinal (or spin-lattice) and transversal (or spin-spin). The relaxation times are usually named T_1 and T_2 .

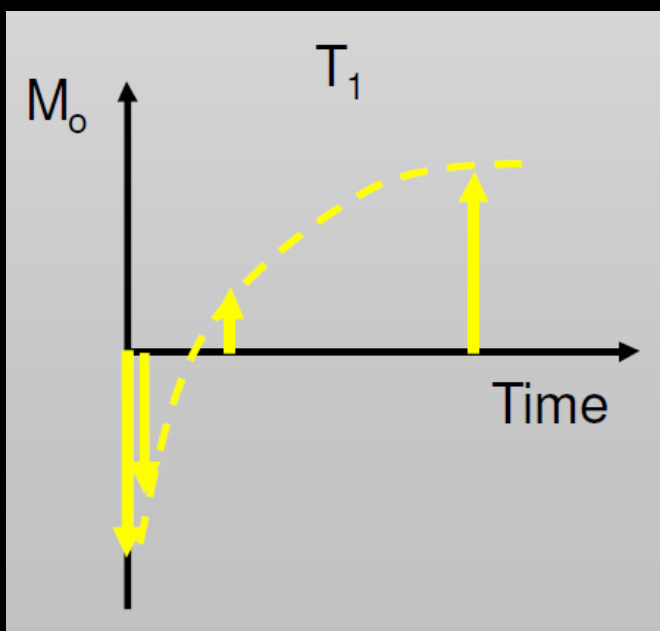

Spin-lattice

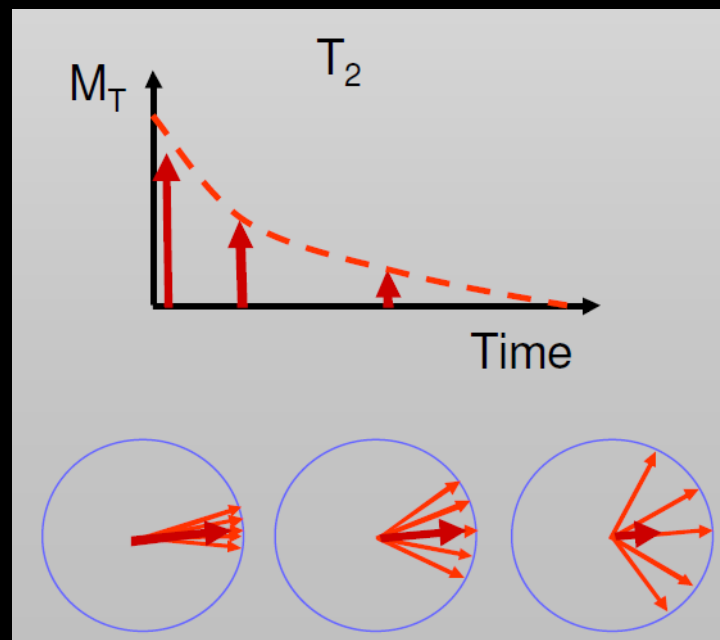

Spin-spin

- Relaxation

- The acquisition of the FID directly after the end of the HF pulse is technically very demanding as a high energy signal just ended and a very weak signal is occurring right after. The so called spin echo comes to help:

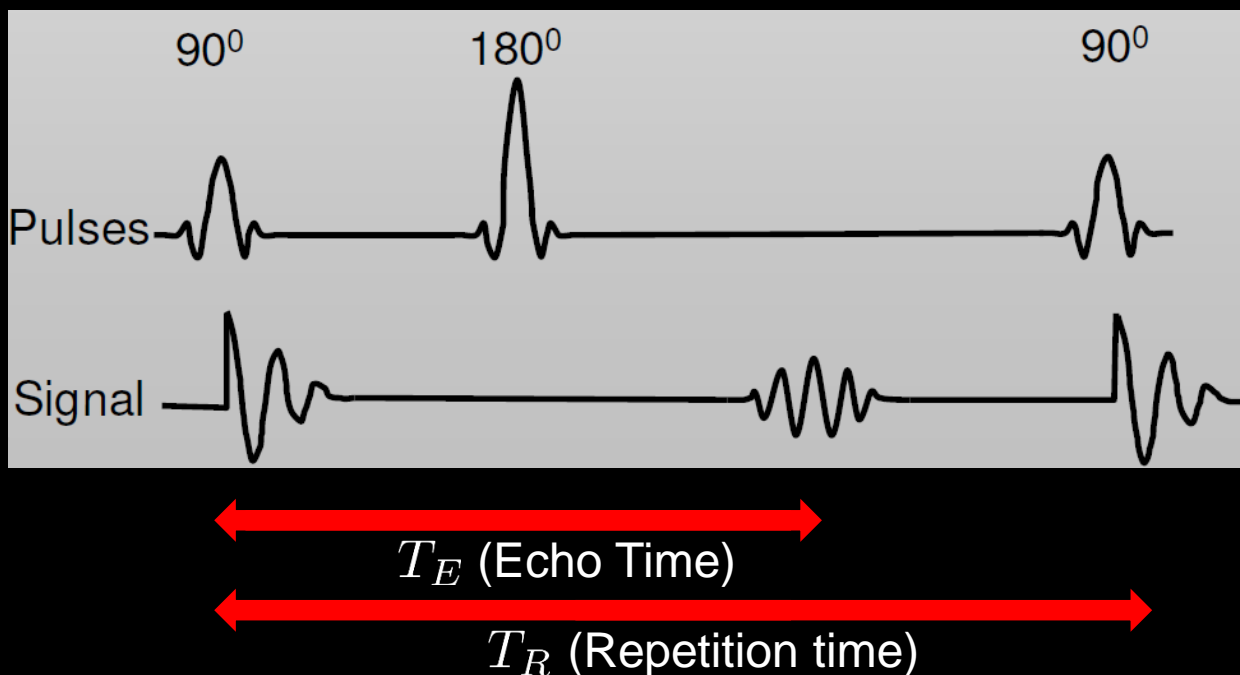

- Z – Encoding (Gradient in Magnetic Field)**

$$\omega(z) = \gamma \cdot \left(B_0 + z \cdot \frac{dG_z}{dz} \right)$$

RF Bandwidth (line slope):
Determine the slice width

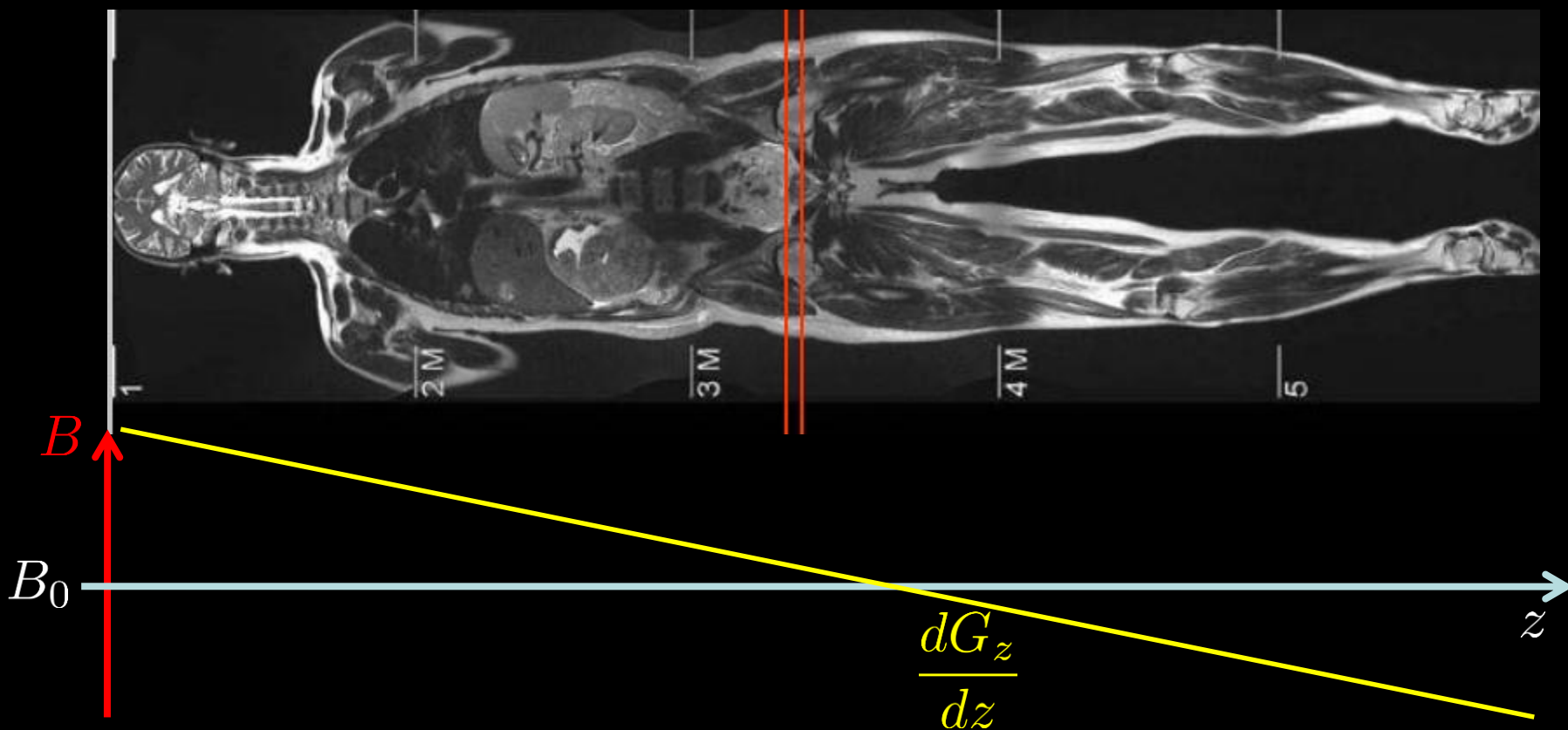

- **Y – Encoding (Phase Gradient)**

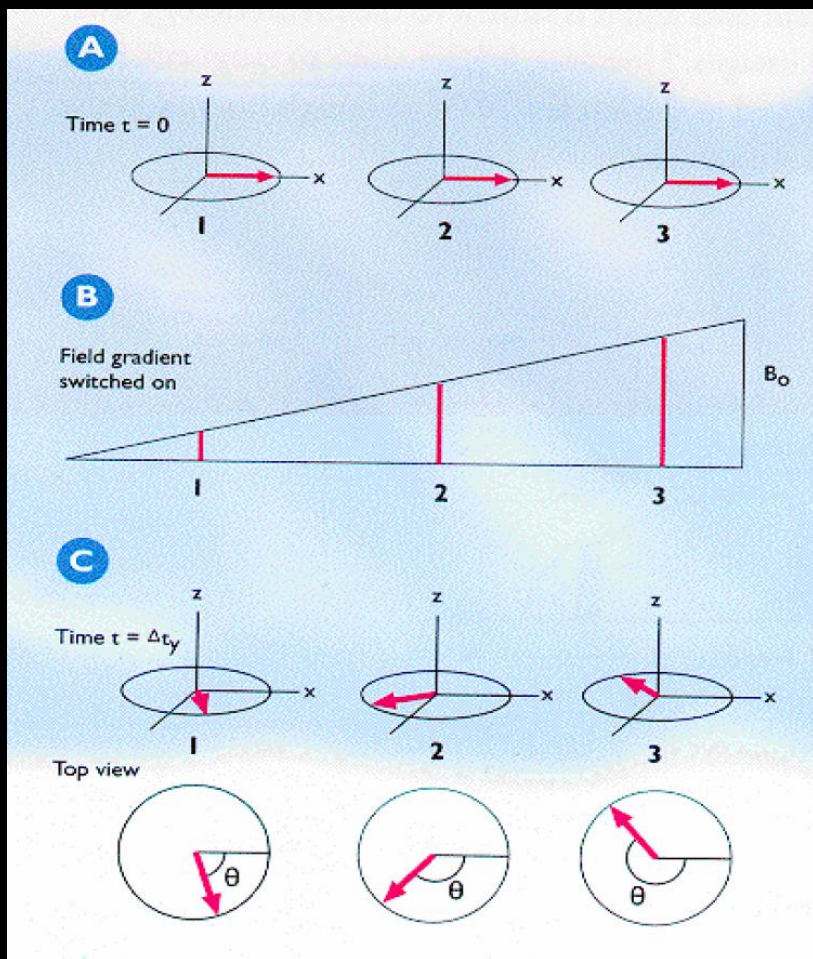

As soon as a slice selective gradient was applied and the spin system is excited, a phase encoding gradient is applied in this preparation phase.

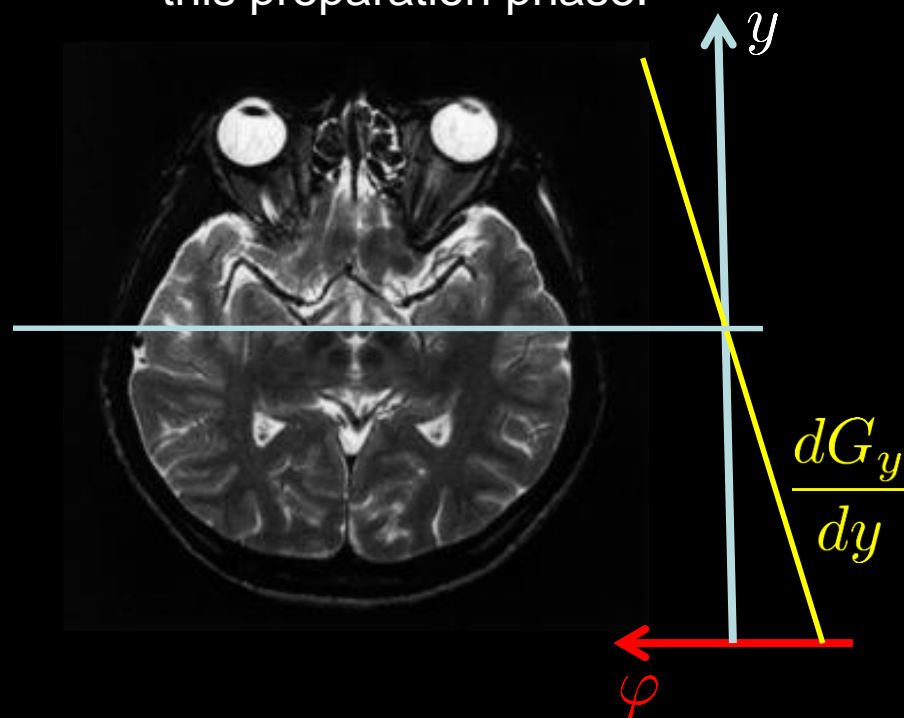

- X – Encoding (Frequency Gradient)**

$$\omega(x) = \gamma \cdot \left(B_z + x \cdot \frac{dG_x}{dx} \right)$$

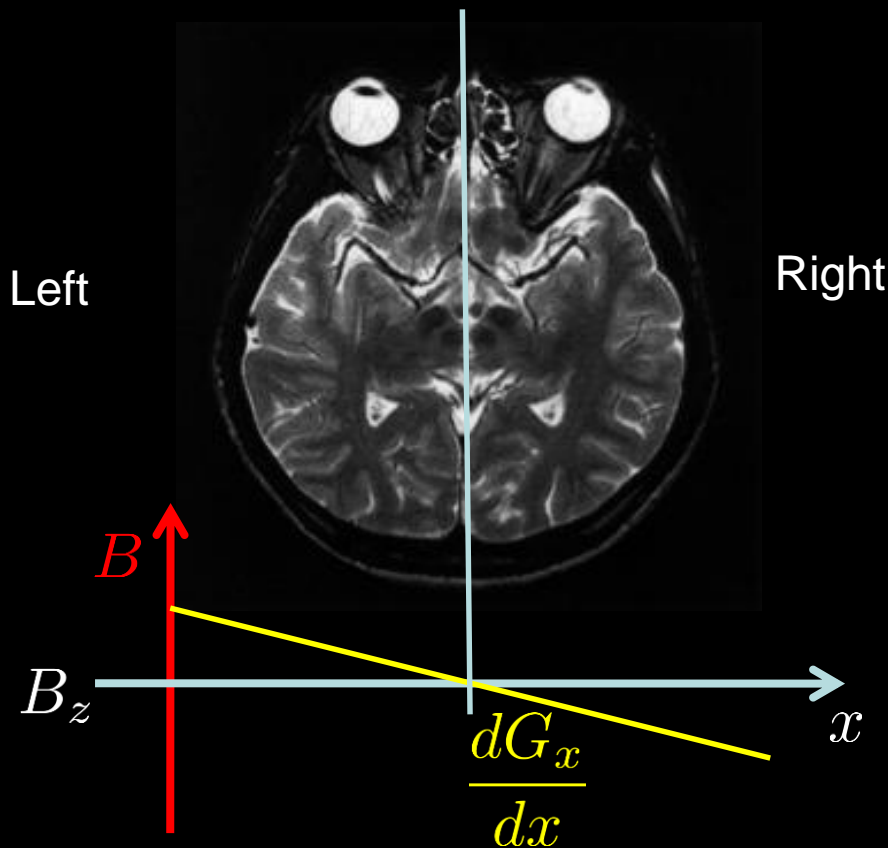

After the preparation phase, the spin system is allowed to relax and the induced signal is measured. However, an x dependent gradient is applied during the “read-out”. Thus, the water molecules emit radiation with spatially varying frequency

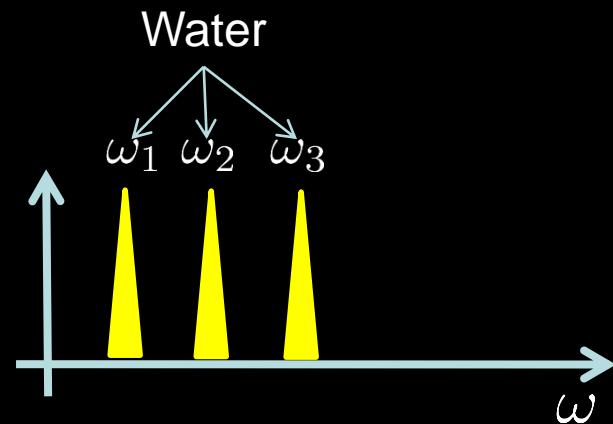

- How are all these individual steps combined ?

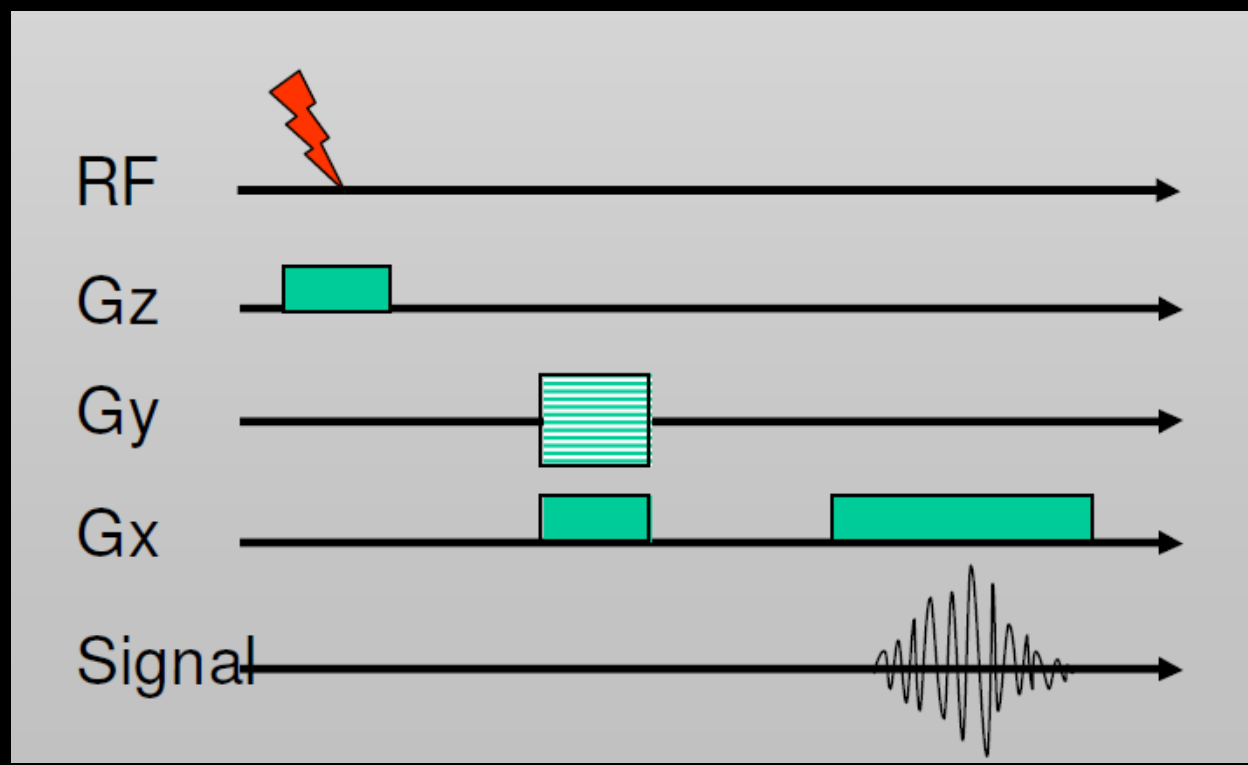

- Image Reconstruction

- Using data only from one slice and coding this information in phase and frequency, we are able to sample to so called “k-space”. Its 2D Fourier transform yields the desired image. Essentially, the 2D FFT separates out the phase shift and the different frequencies

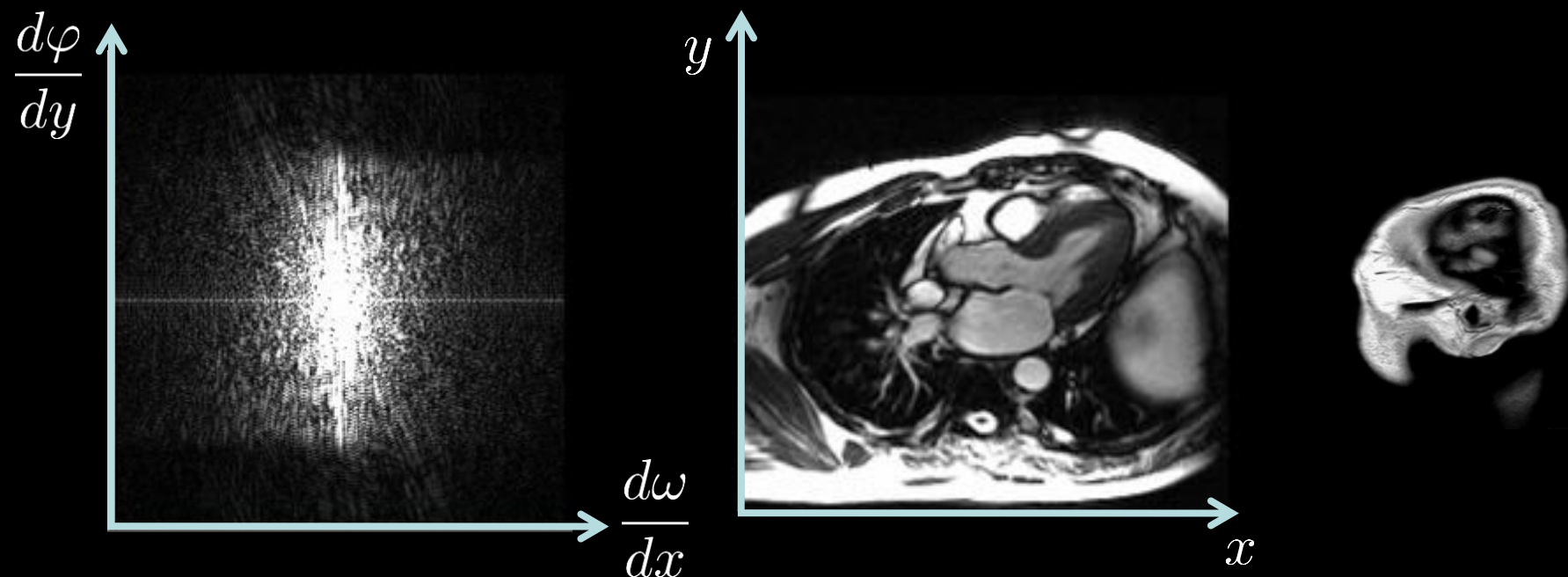

- Hardware
0.1 T Philips 1979



1.5 T Siemens 2000



Length: 2m
Weight: 4 tons

3.0 T Siemens 2003

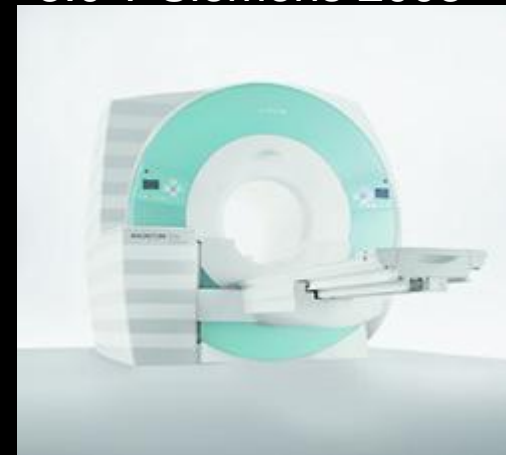

7 T Siemens 2005



Length : > 3m
Weight : 32 tons



15.2T, 11.7T, 9.4 T Bruker 2012
(Small Animal MRI)

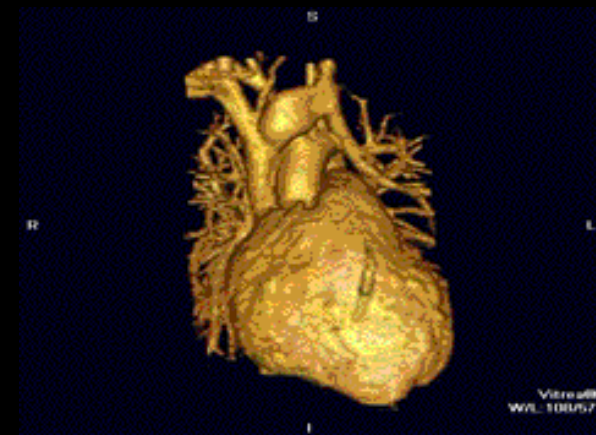

Wikipedia

- Why MRI?

- No ionizing radiation

- Hardly any side effects, few contra indications
- Works even in children and anesthetized patients
- May be applied in serial examinations

- Excellent image quality

- High biological contrast
- High resolution in arbitrary orientation
- Mature technology

- Relatively easy to set up

- Low maintenance

- Still advances happening and possible

- Good reimbursement

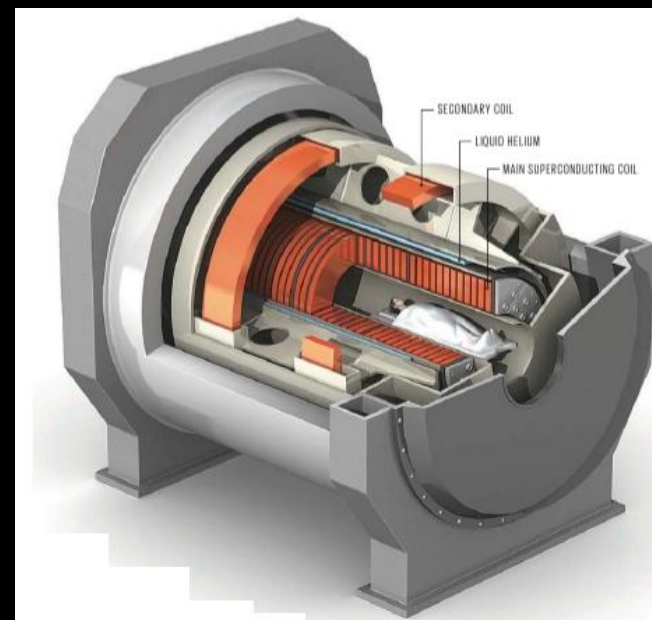
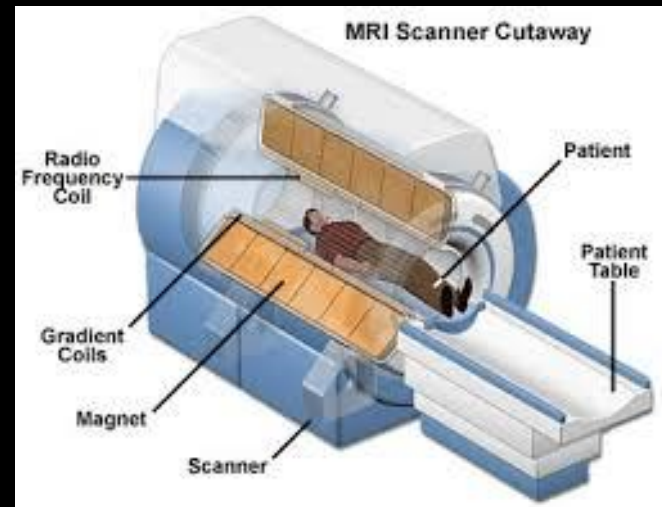

- The energy used in US is sound (pressure) waves.
- Sound waves need material environment for propagation.
- Their motion in material depends on the materials property.
- They can be altered/reflected by the materials they are moving inside.
- We can use these alterations as an information source about the materials (tissues).

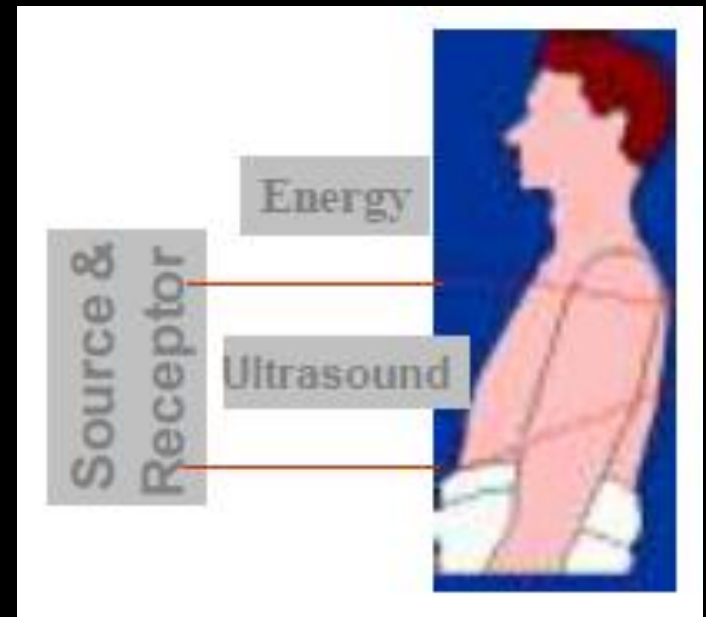

- What is Ultrasound?

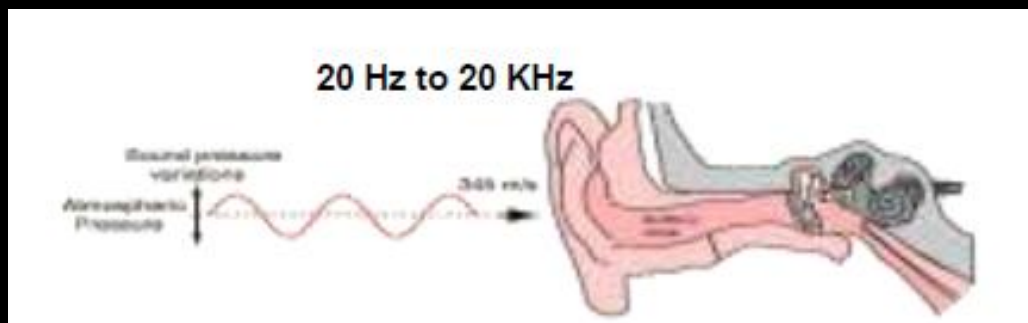

Ultrasound is any sound emitted at a **frequency > 20 KHz.**

- Medical ultrasound uses frequencies in the range of 500 KHz to 30 MHz.
- For imaging 1MHz to 10 MHz.
- Intravascular imaging up to 30 MHz. (Higher the frequency better the resolution!!)

- Examples of ultrasound probes (Piezoelectric elements)

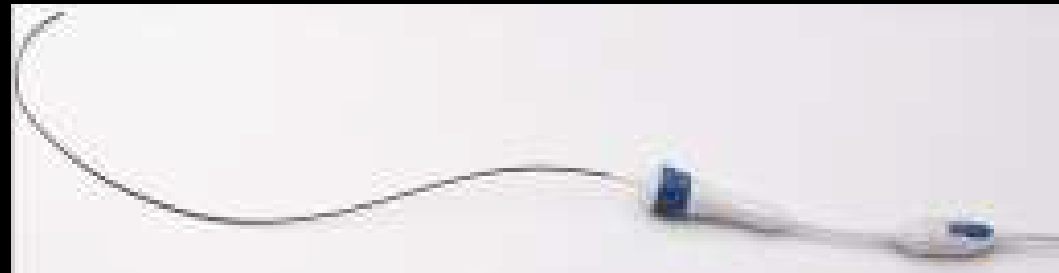

- Therefore, to generate an ultrasound image:
 1. Generate ultrasound signal and send it into the tissue.
 2. Record the echoes (RF signals) returned back from the tissue (by ultrasound recording element) .
 3. Process the RF signal and extract information .
 4. Demonstrate the results (there are different methods) .

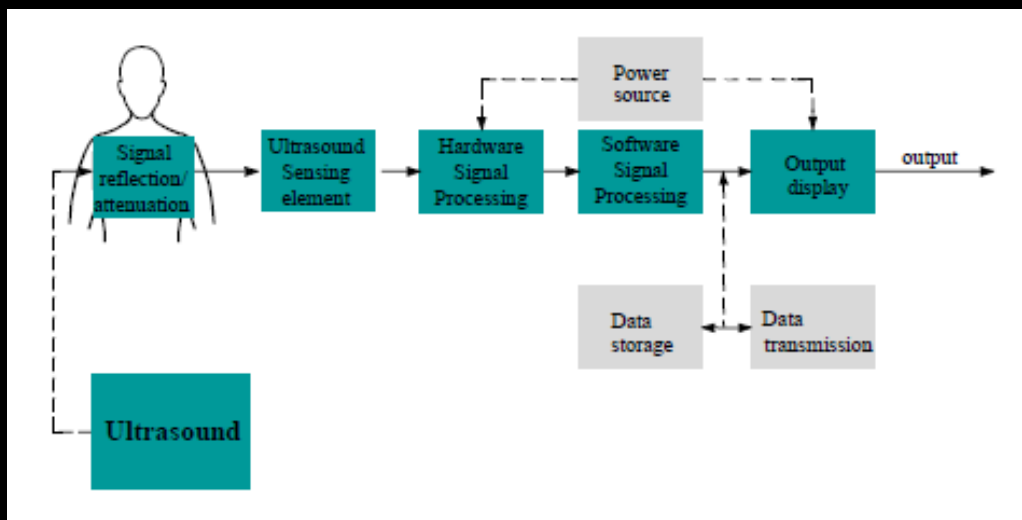

- Workflow

1. An ultrasound probe is used to generate a short burst of the ultrasound signal, which is sent into the tissue.

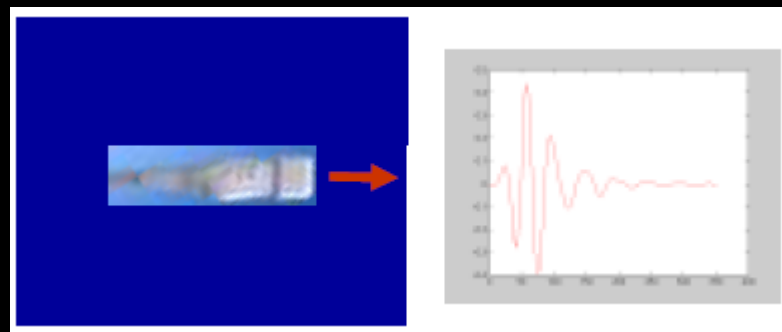

2. The same ultrasound probe is usually used to Record the echoes (RF signals) returned back from the tissue.

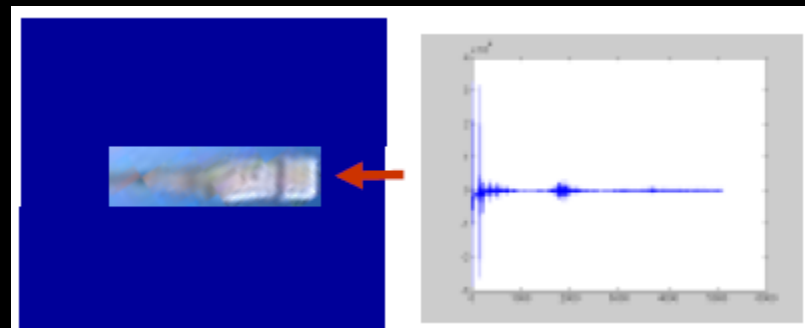

Different tissues show different reflection properties.

- The sound speed in soft tissue is about 1540 m/s
- As round-trip increases, reflector's distance increases
- For $c = 1540 \text{ m/s} = 1.54 \text{ mm/s}$:

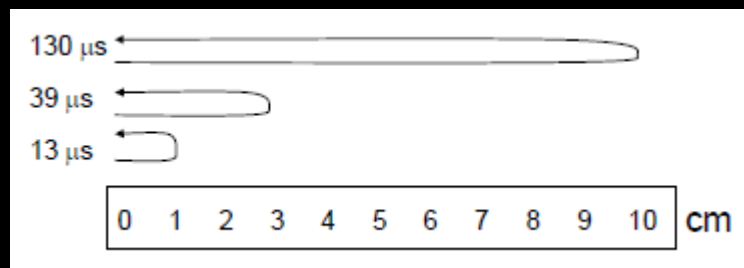

3. Processing the RF signals

- Envelope detection by Hilbert Transform
- Dynamic range reduction by *log function*
- Decimation for data reduction (5100 samples into 300 samples)

- Examples:



Foot

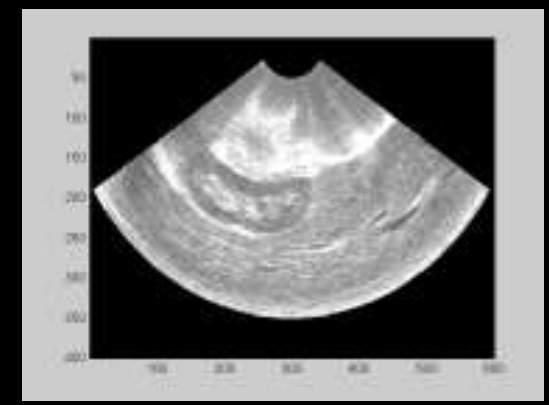



Activity distribution equivalent to distribution of the injected substance.

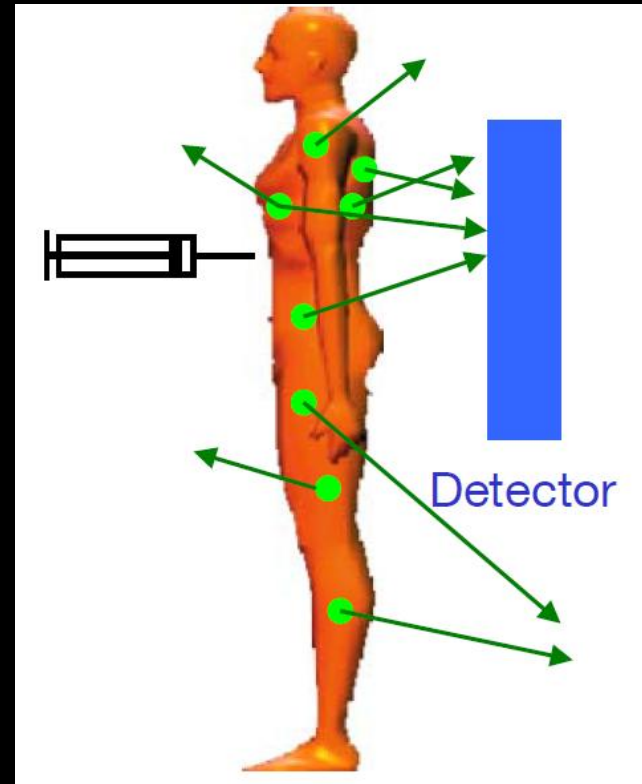

Nuclear Medicine

- Radioisotop

What do we want:

- not too short and not too long half life time
- only γ radiation (α & β would increase patient dose without gain for diagnosis)

Nuclide	Half life time	Decay	Energy
^{99m}Tc	6 h	γ	140 keV
^{201}Tl	73 h	γ	70 keV
^{123}I	13 h	γ	159 keV
^{18}F	110 min	e^+ , $\gamma \gamma$	511 keV
^{11}C	20 min	e^+ , $\gamma \gamma$	511 keV
^{13}N	10 min	e^+ , $\gamma \gamma$	511 keV

- **Radiopharmaceuticals**

- The radioisotope has to be connected (labelling) to a pharmaceutical based on the organ specific question.
- Radiopharmaceuticals should not disturb the process under investigation.
- e.g. FDG (¹⁸F-Fluorodesoxyglucose) to analyze the Glucose metabolism

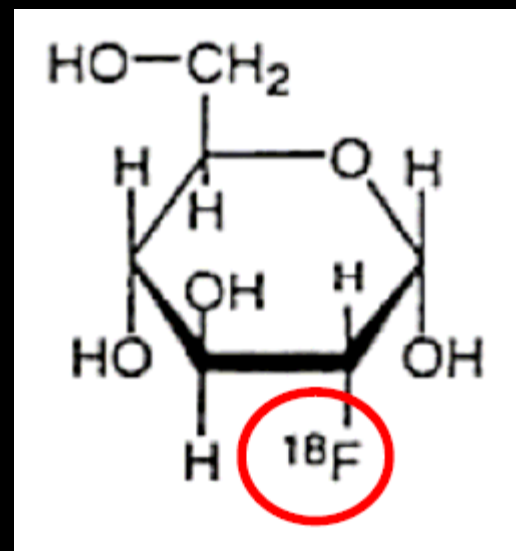
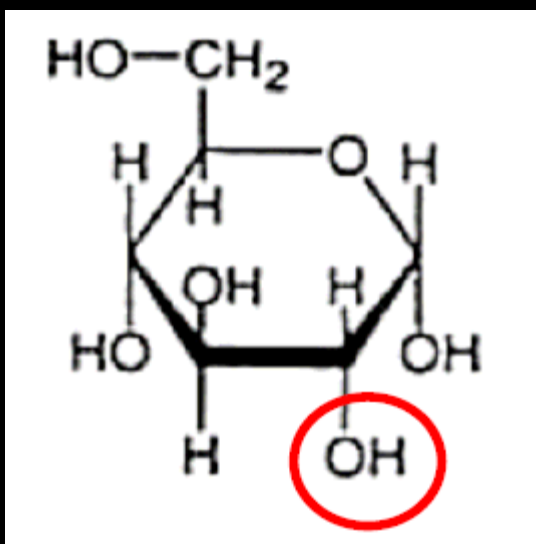

- **Tracer principle**

- The tracer (radiopharmaceutical) takes part in the metabolism of investigation
- The tracer may not disturb the process under investigation
- Possible due to the high sensitivity of the devices,
- e.g. ^{18}F -FDG – typical dose: 370 MBq

	CT	MRT	Nuc Med
Resolution (mm)	< 1	< 1	5 – 15
Sensitivity (ng/l)	1000 000	1000	1-10

- **Radiation-Detection**

- Scintillators, e.g. NaI(Tl) – Thallium doped Sodium Iodide

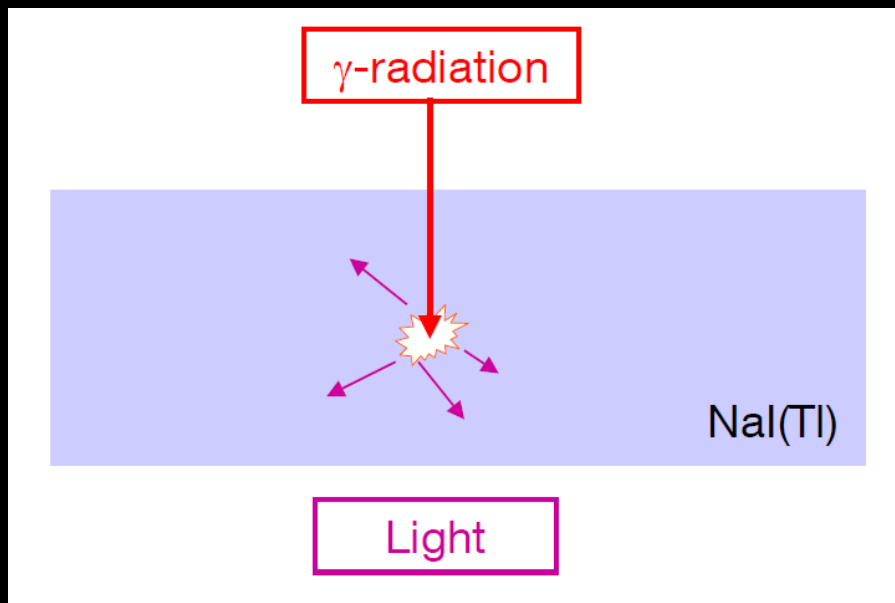

- Gamma camera

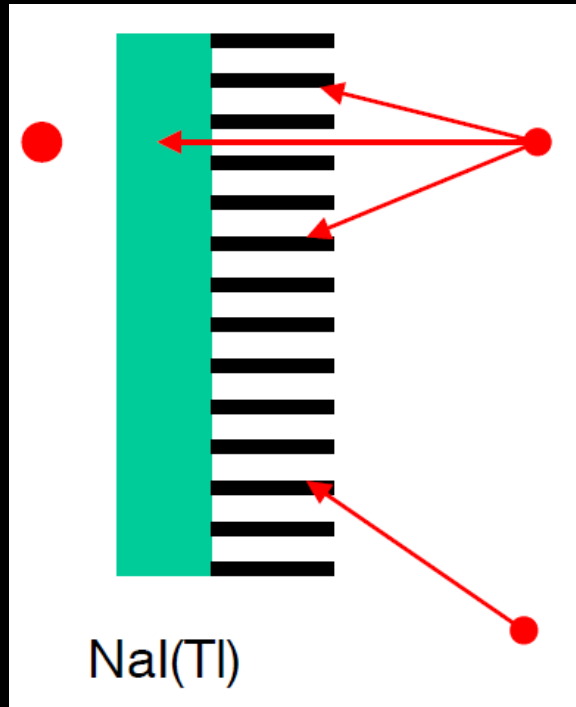

Collimators are chosen depending on sensitivity and resolution necessary for an particular examination.

- Photo multiplier
 - multiply the signal produced by incident
 - light by as much as 100 million times

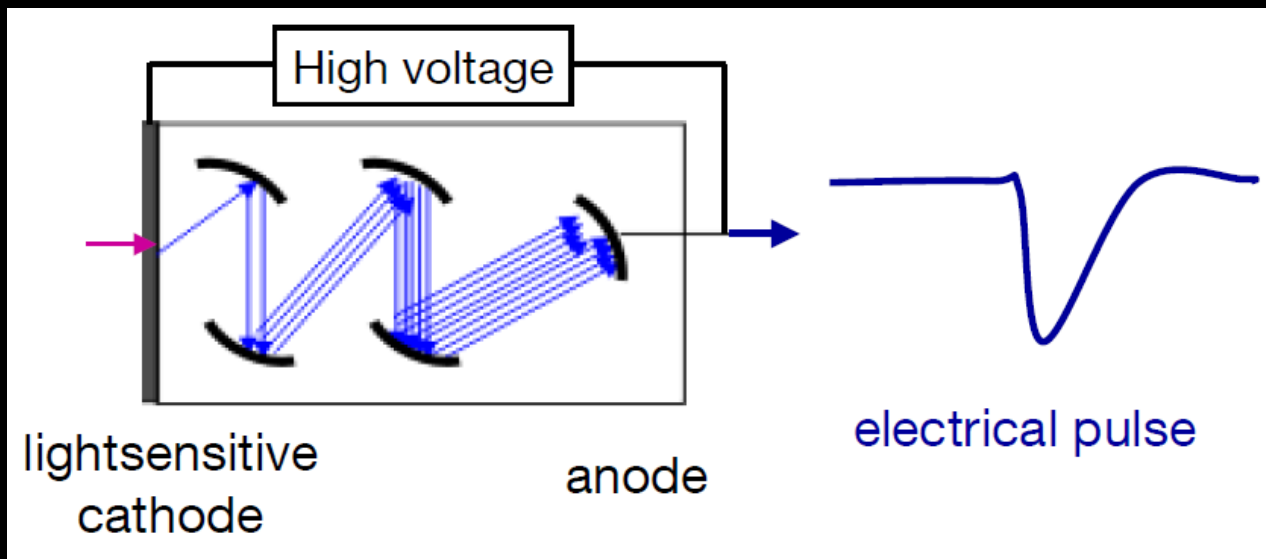

γ -energy ~ light ~ pulse height

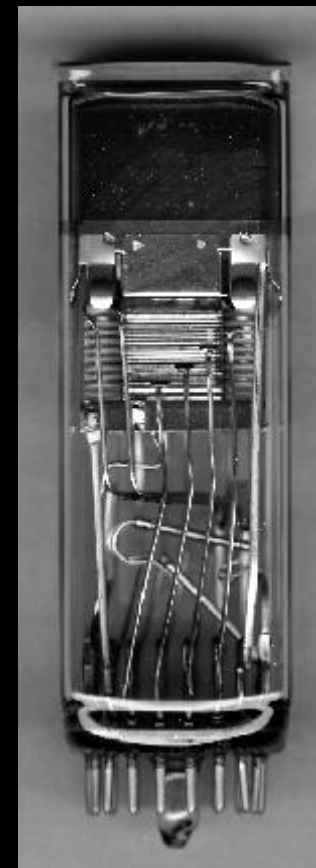

- **Single Photon Emission Tomography – SPECT**
 - Gamma camera rotating around the patient

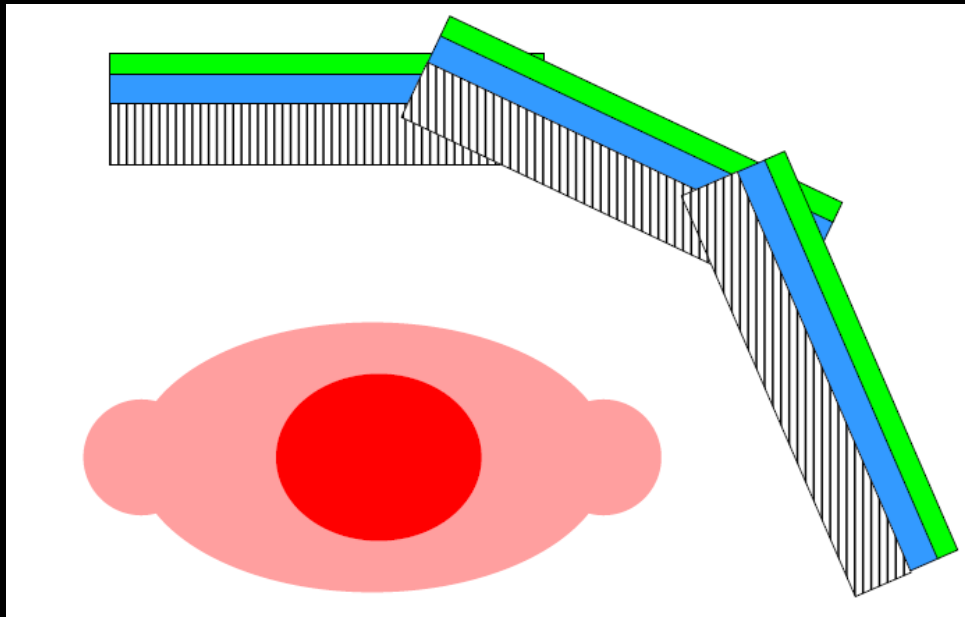

- **Single Photon Emission Tomography - SPECT**

- Myocard SPECT – ^{99m}Tc MIBI (methoxyisobutylisonitrile) myocardial perfusion in cardiac rest and stress for diagnosis and staging (prognostic factor) of coronar disease

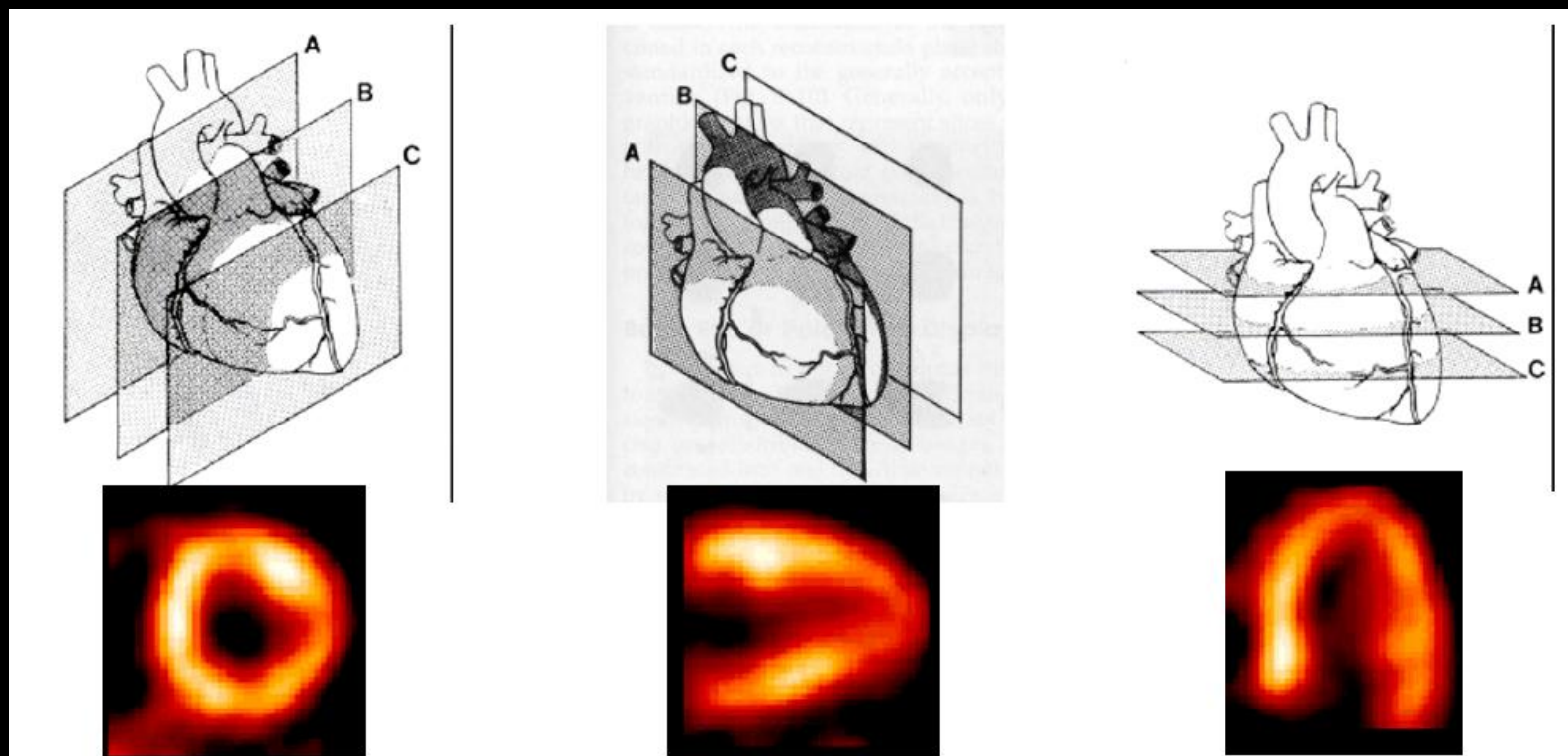

- **Positron Emission Tomography – PET**

- Positron decay:

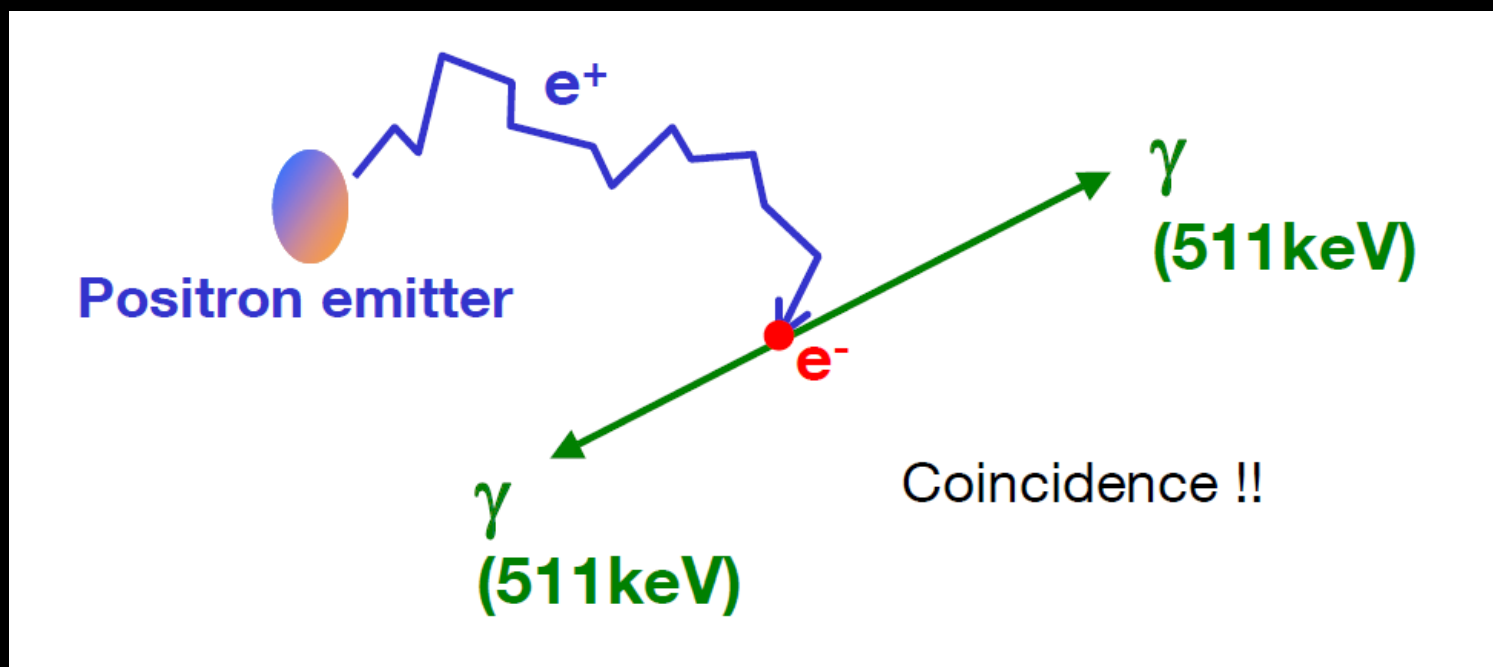
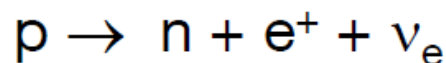
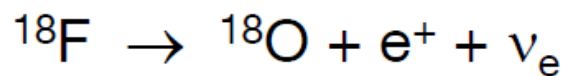

- **Positron Emission Tomography – PET**
 - Coincidence events are registered by a detector ring around the patient:

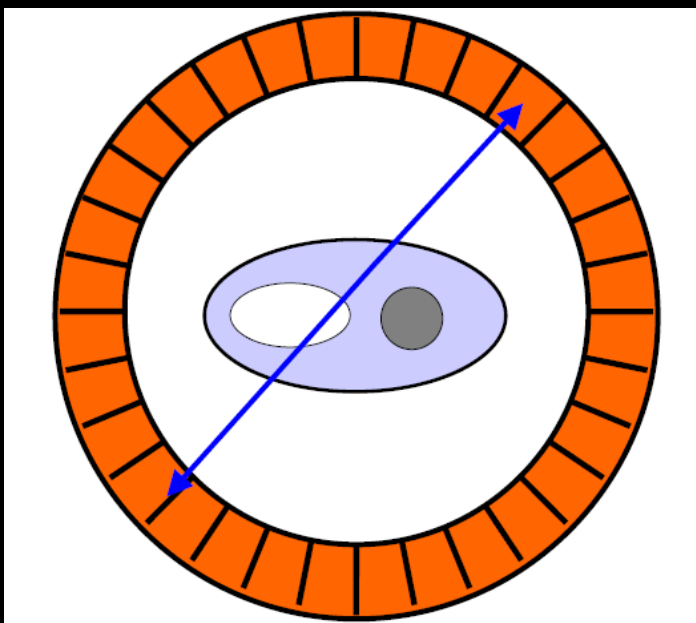

No collimator necessary -
electronic collimation!

Use of all coincidence lines
(→ projections)

- **Positron Emission Tomography - PET**
 - Absolute activity concentration

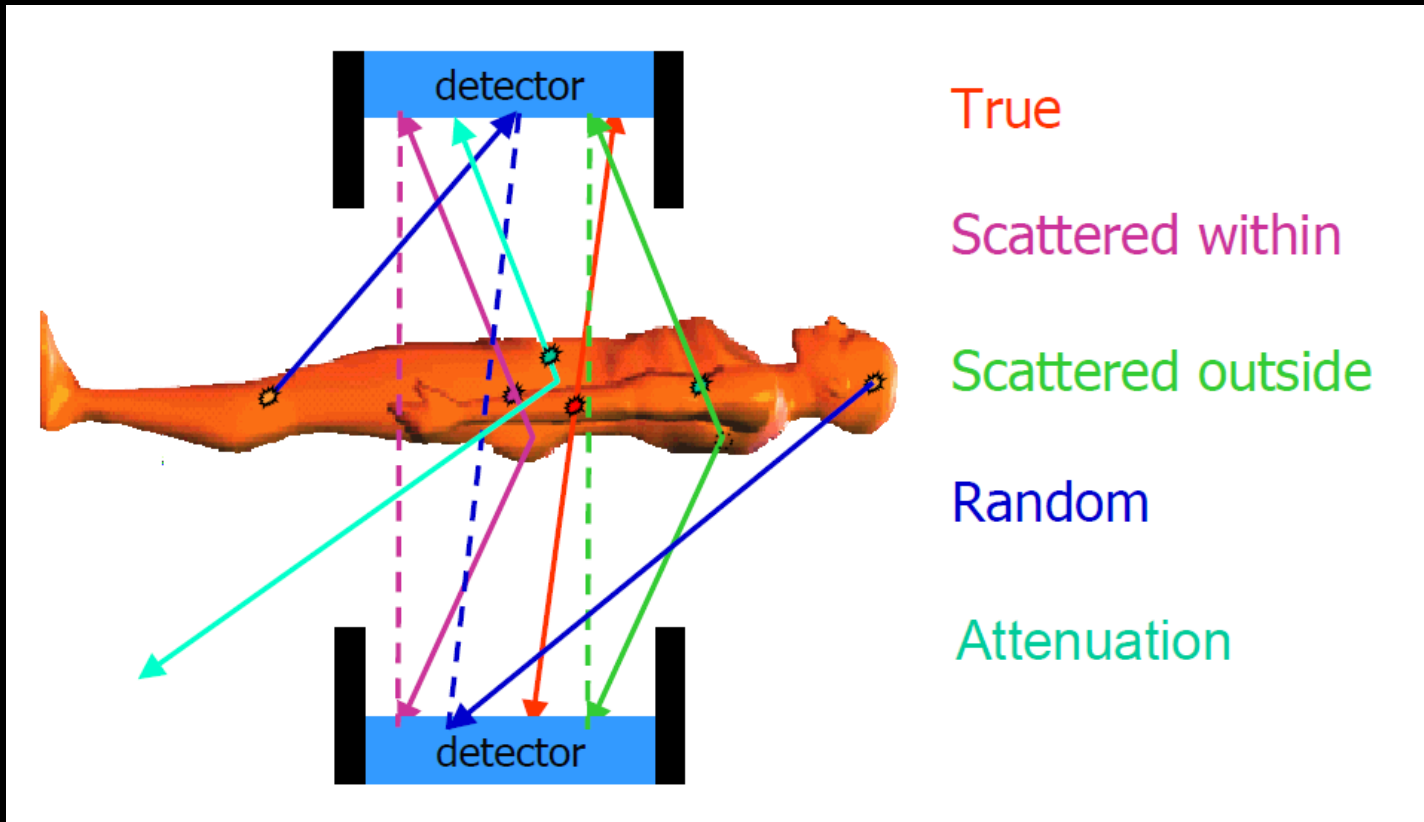

- **Positron Emission Tomography - PET**
 - Attenuation

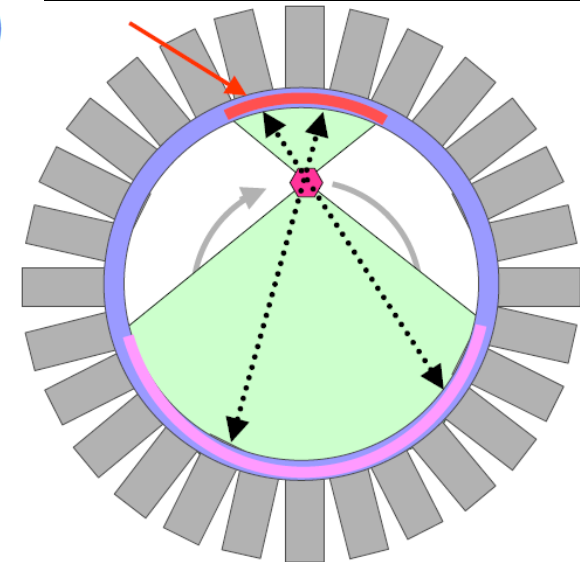
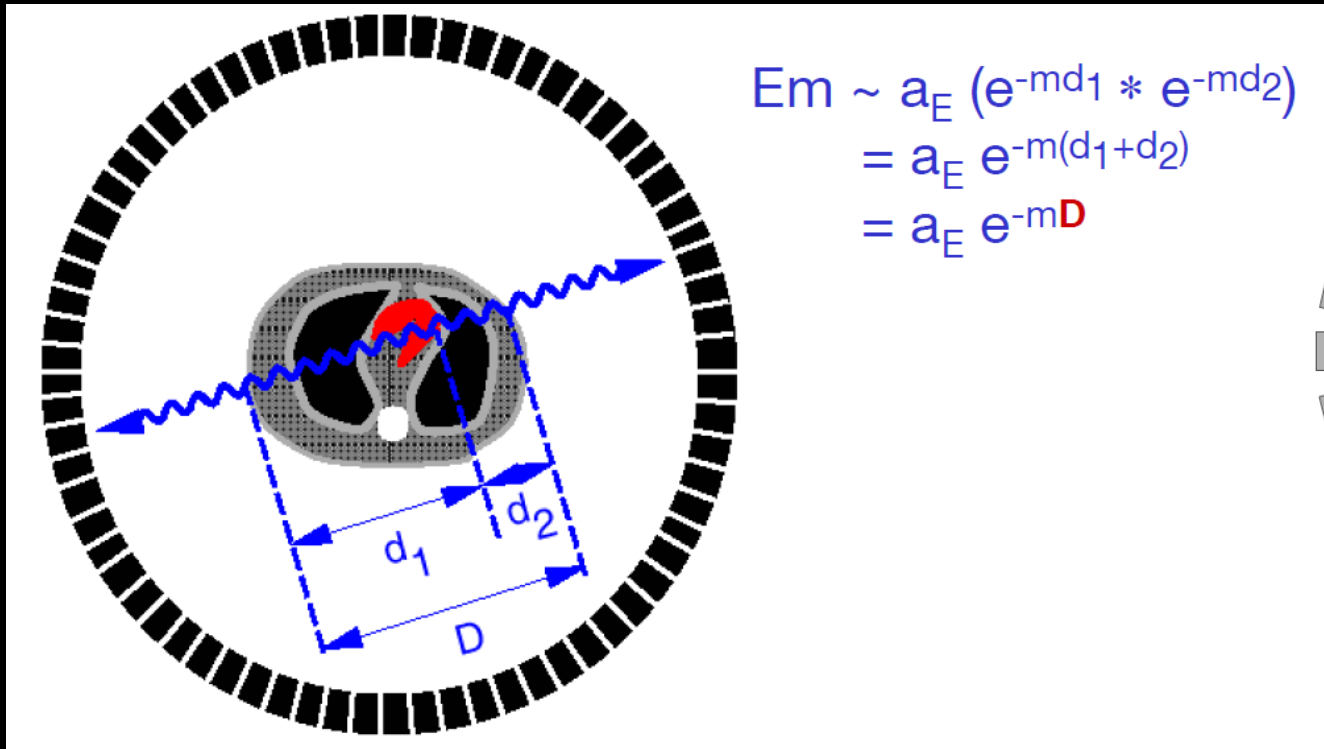

- **Multimodality – PET/CT**

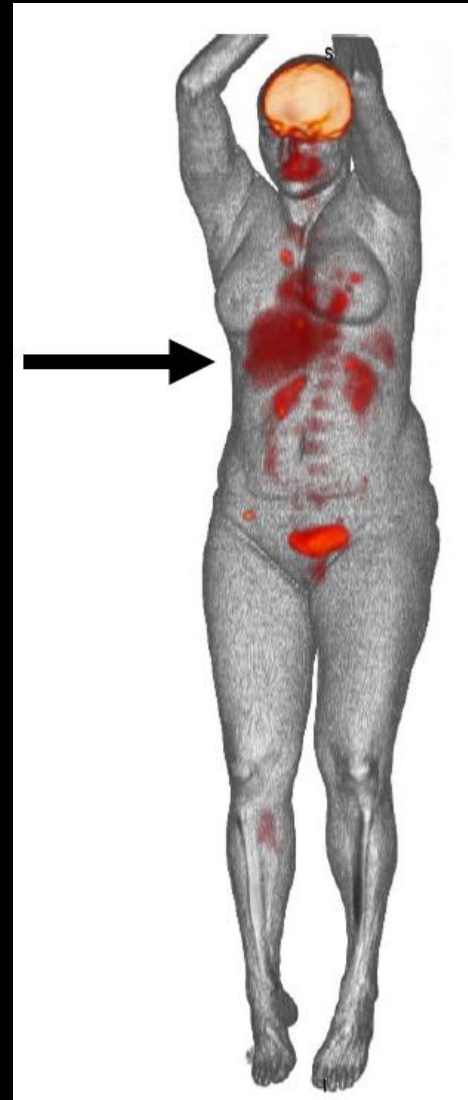
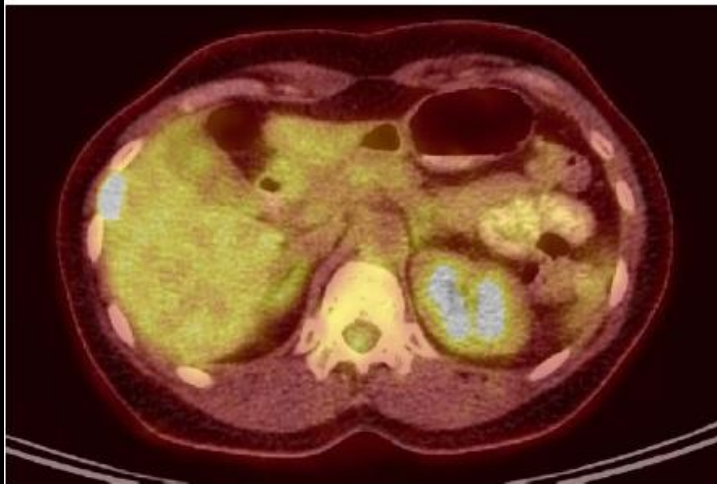
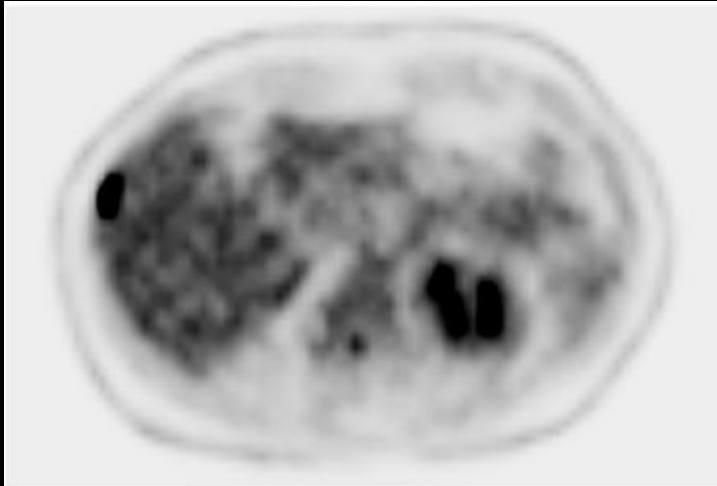

- **Multimodality – PET/MR**

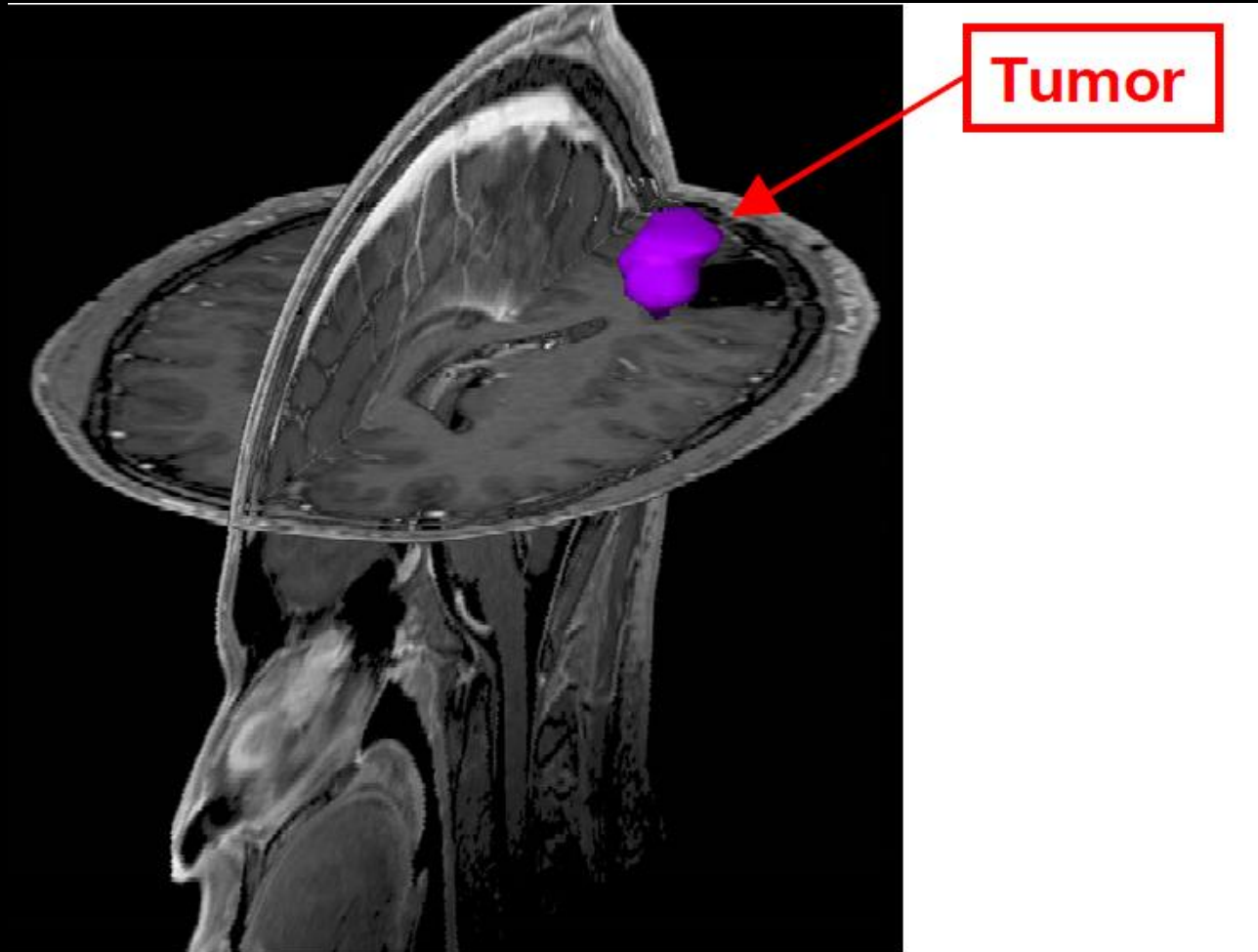

- Digital Imaging and Communications in Medicine (DICOM)
 - standard for handling, storing, printing, and transmitting information in medical imaging
 - File format
 - Network communications protocol
 - Owned by National Electrical Manufacturers Association (NEMA)

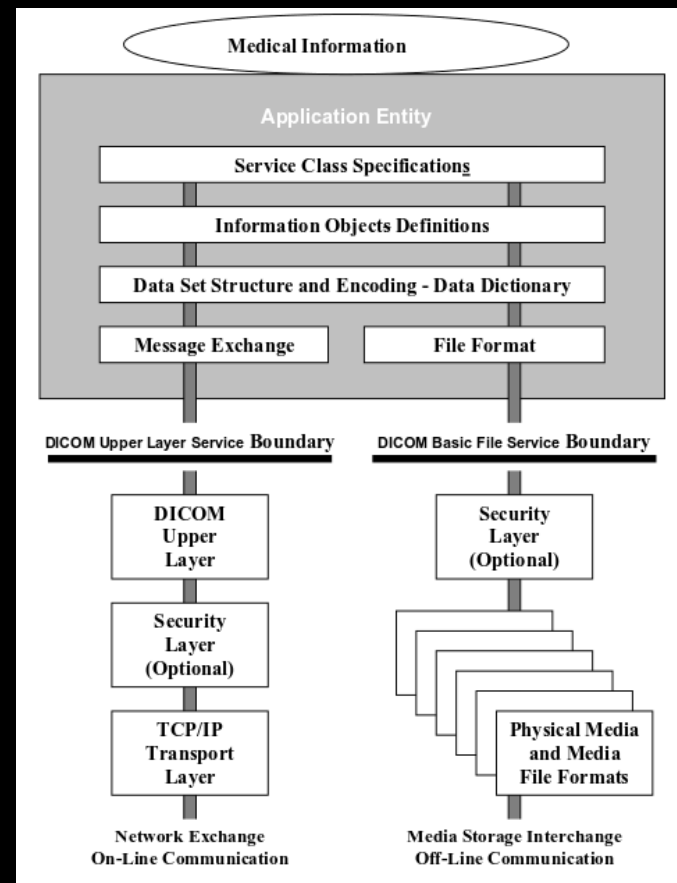

<http://medical.nema.org/Dicom/2011/>

- Tomographic Imaging

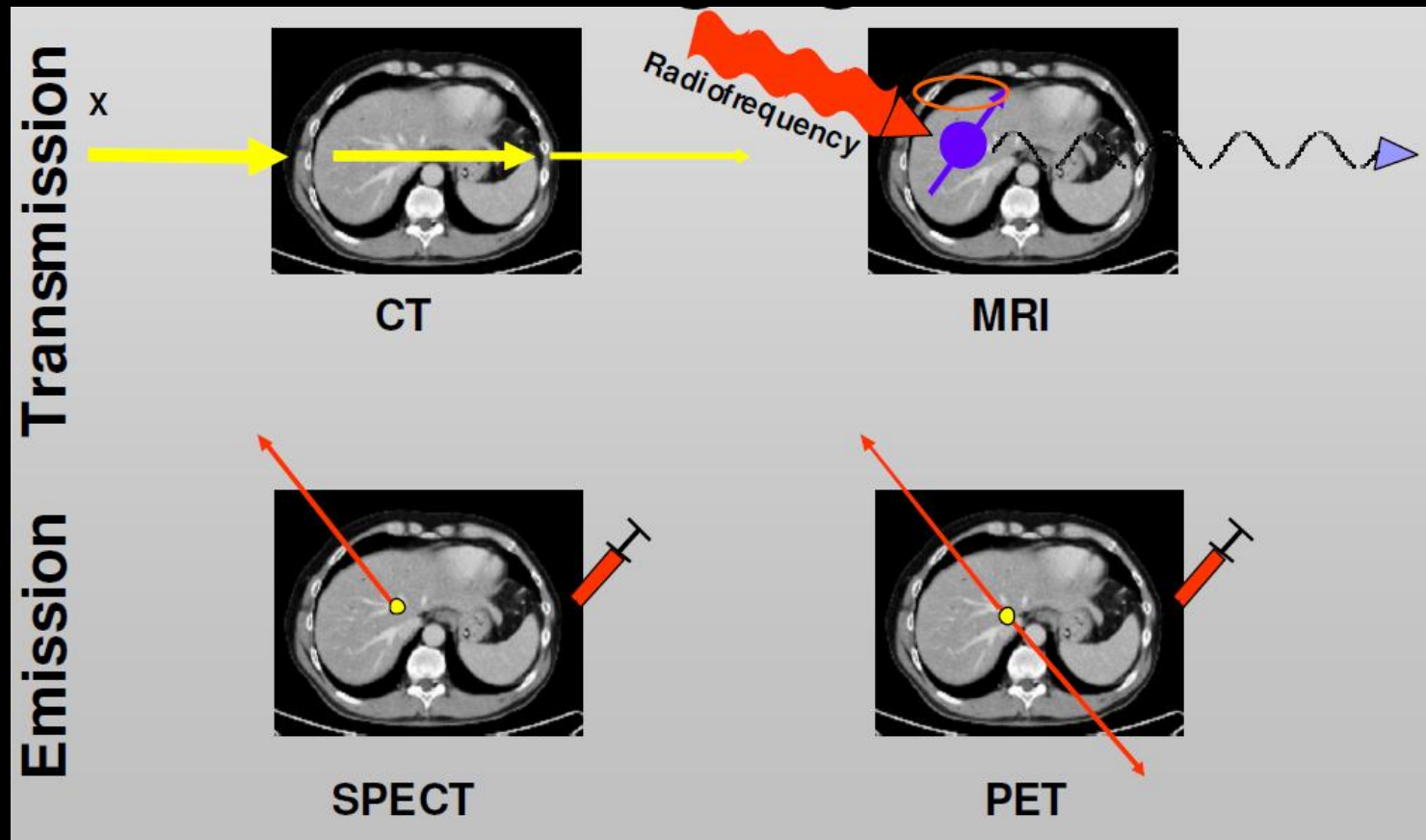

- Examples of Tomographic Imaging

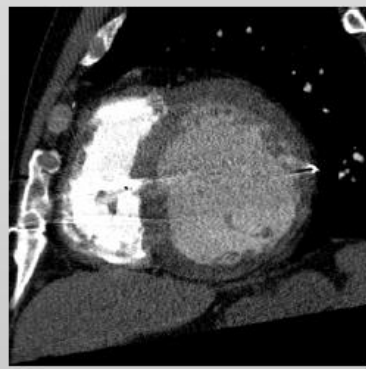

CT

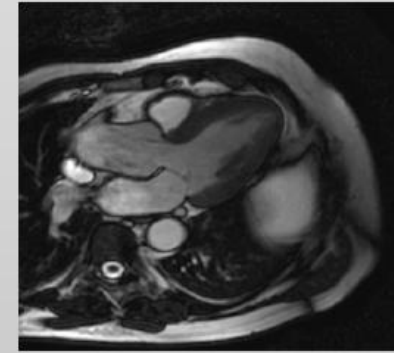

MRI

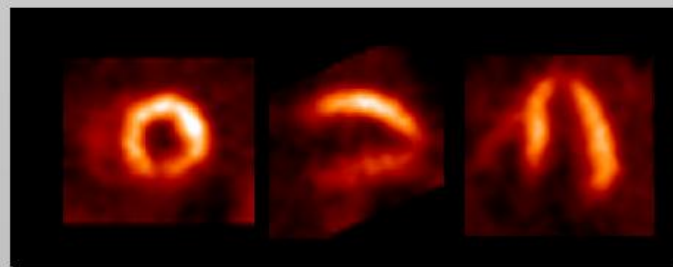

SPECT

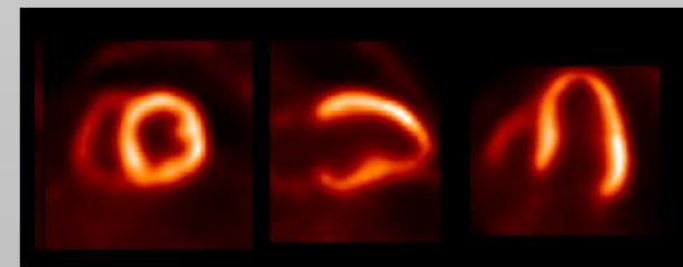

PET

- Tomographic Imaging

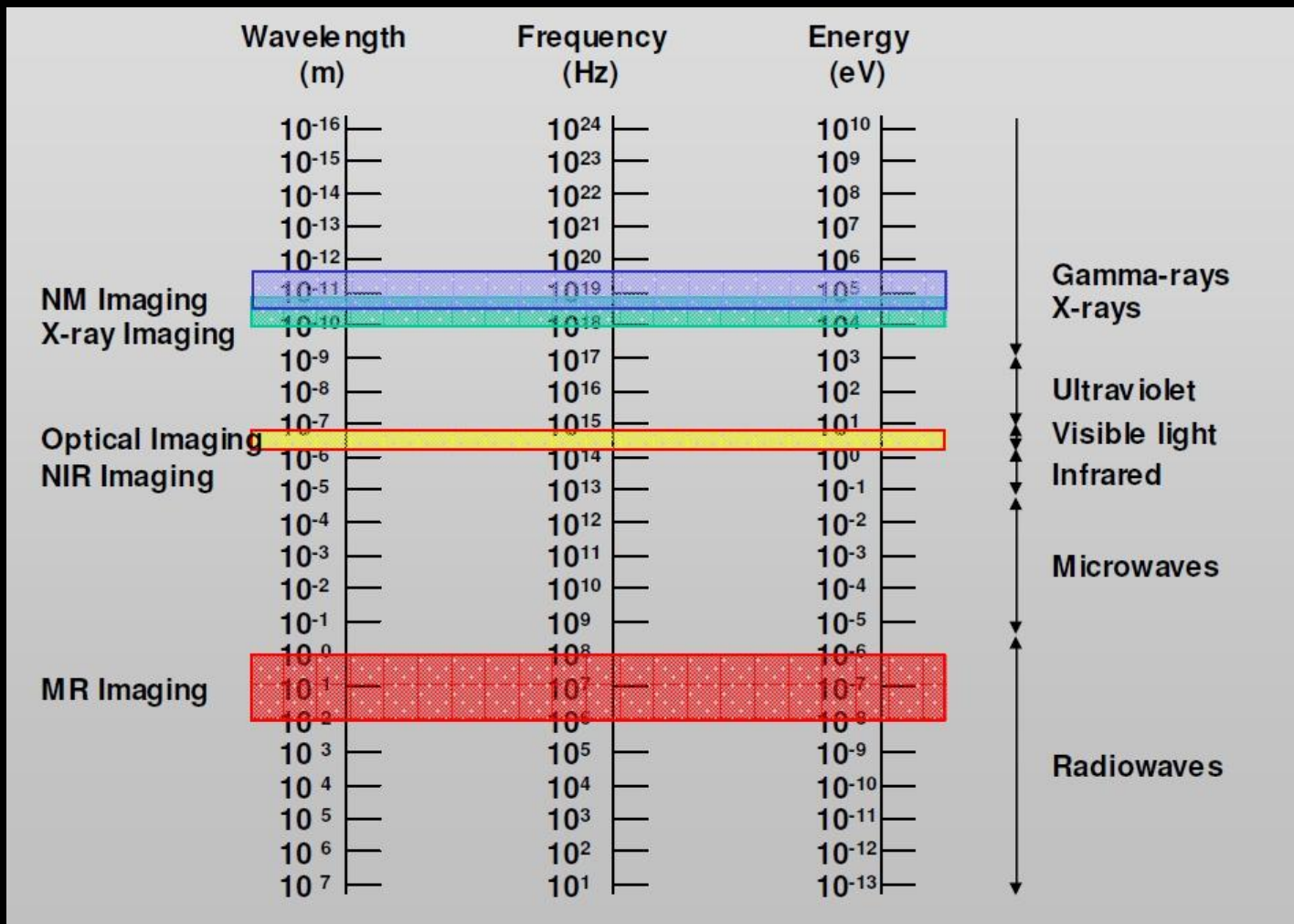

- CT Scan
 - Suited for bone injuries, Lung and Chest imaging, cancer detection
 - Provides good details about bony structures
 - Usually completed within 5 minutes
 - Risk of irradiation (Moderate to high radiation)
- MRI
 - Suited for ligament and tendon injury, spinal cord injury, brain tumors
 - Scanning typically run for about 30 minutes.
 - High detail in the soft tissues
 - No biological hazards have been reported
 - Patients with Cardiac Pacemakers are not allowed

- Computer Assisted Medical Procedures Lecture, Dr. Prof. Navab, Technical University of Munich.
<http://campar.in.tum.de/>
- PhD. Thesis, Dr. Lange, University of Siegen