

Curso Binacional 2023
Uruguay - Chile

Microscopía para el Estudio de Biofilms Bacterianos

Instituto de Investigaciones Biológicas Clemente Estable (IIBCE)
Instituto de Neurociencia Biomédica (BNI), ICBM, F-Med, U-Chile

2 - 6 de octubre - Teórico
9 - 13 de octubre - Práctico Uy,
10 de octubre - 3 de noviembre - Práctico Cl.



Prof. Dr. Steffen Härtel

www.scian.cl / www.cimt.cl / www.cens.cl www.bni.cl / www.rsdue.cl

Laboratory for Scientific Image Analysis (SCIAN-Lab)
Centro de Informática Médica y Telemedicina (CIMT)
Centro Nacional en Sistemas de Información en Salud (CENS)
Biomedical Neuroscience Institute (BNI)
Red de Salud Digital de Universidades del Estado (RSDUE)
Institute of Biomedical Sciences (ICBM)
Anatomy and Developmental Biology Program
Escuela de Postgrado
Facultad de Medicina, Universidad de Chile

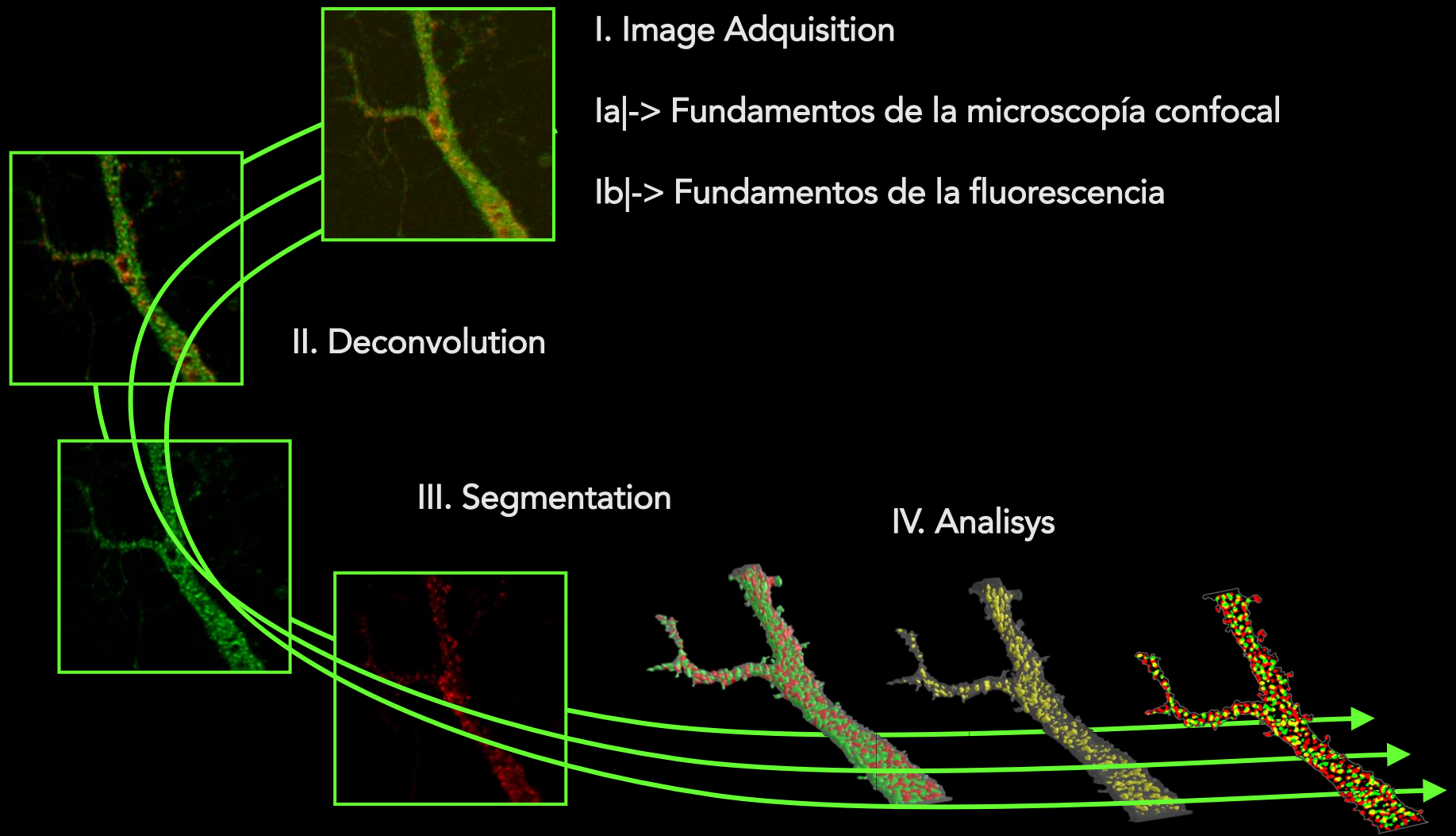

• Links & Software



Links de interés:

- Latin American Bioimaging: <https://labi.lat/es>
- Global Imaging : www.globalimaginginc.com
- La Red de Equipamiento Científico Avanzado: <https://redeca.med.uchile.cl>
- Microscopy Australia: <https://myscope.training>
- The Scale of the Universe <https://htwins.net/scale2>
- Photomultiplier www.olympus-lifescience.com/en/microscope-resource/primer/digitalimaging/concepts/photomultipliers
- Chrome Spectra Viewer www.chroma.com/spectra-viewer
- Thermo Fisher Spectra www.thermofisher.com/order/spectra-viewer

Software para bajar & instalar:

1. Huygens Deconvolution (SVI): https://svi.nl/tiki-login_scr.php
2. FIJI, ... is an image processing package: <https://fiji.sc>
3. Icy, ... an open community platform for bioimage informatics: <http://icy.bioimageanalysis.org>

• Links & Literatura

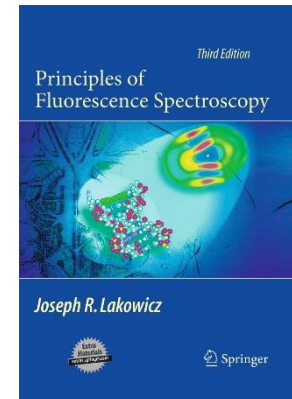
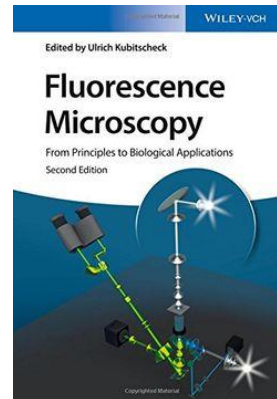

- The Good, the Bad and the Ugly. Helen Pearson. 2007 Nature 447:138-140
- Seeing is believing? A beginners' guide to practical pitfalls in image acquisition. Alison J. North. 2006 The Journal of Cell Biology, 172(1):9-18
- V Castañeda, M Cerda, F Santibáñez, J Jara, E Pulgar, K Palma, ... [Computational methods for analysis of dynamic events in cell migration](#), Current molecular medicine 14 (2), 291-307
- Fluorescence Microscopy, From Principles to Biological Applications, Ulrich Kubitschek (Editor), 2nd Edition, June 2017, Hardcover, ISBN: 978-3-527-33837-5
- <https://www.zeiss.com/microscopy/int/cmp/edr/21/microscopy-for-dummies.html>
- <https://www.microscopyu.com/tutorials>
- <http://zeiss-campus.magnet.fsu.edu/tutorials/index.html>
- <https://www.leica-microsystems.com/science-lab/topics/basics-in-microscopy>
- https://www.youtube.com/playlist?list=PLG8B8Uyfh7-Azddns5nv_kZU1YQGD4bBg
- Principles of Fluorescence Spectroscopy, Joseph R. Lakowicz 4.1 Introduction to Fluorescence
- [A global view of standards for open image data formats and repositories](#) JR Swedlow, P Kankaanpää, U Sarkans, W Goscinski, G Galloway, ..., Nature Methods, 1-7
- Jonkman, J., Brown, C.M., Wright, G.D. et al. Tutorial: guidance for quantitative confocal microscopy. Nat Protoc 15, 1585–1611 (2020), <https://doi.org/10.1038/s41596-020-0313-9>

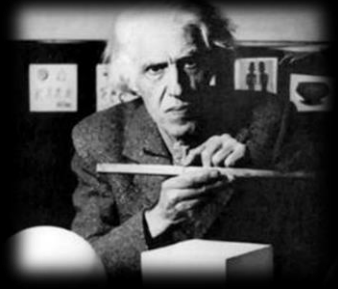

Joaquín Torres García 1874-1949



Richard Feynman (1918-1988)



Mats Gustafson 2006 - 2011



René Descartes (1596-1650)



Maria Goeppert-Mayer 1906-1972



Ernst Abbe 1840- 2005



E Betzig



S Hell



W Moerner

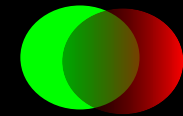
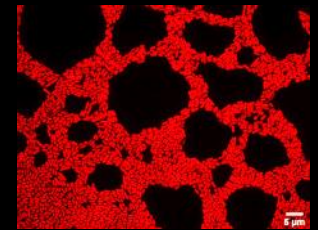
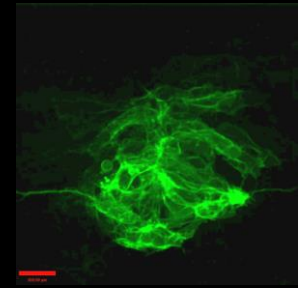
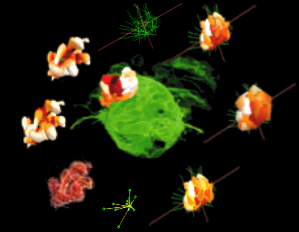
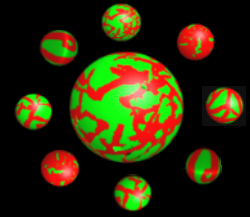
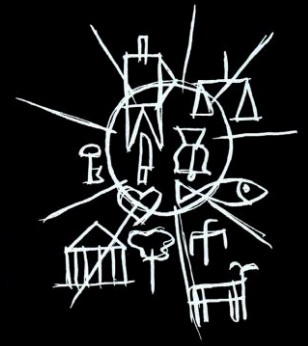



- Prof Dr Steffen Härtel, Biofísico, Dr. rer. nat. Director SCIAN-Lab



- Prof Dr Mauricio Cerda, Ing. Civil en Computación PI SCIAN-Lab



- Prof Dr Victor Castañeda, Ing. Civil Eléctrico, PI SCIAN-Lab / DTM



- Dr Jorge Jara, Ing. Civil en Informática, PostDoc SCIAN-Lab



- MSc Constanza Vásquez, Ing. Biomédica, Computación



- MSc Roberto Rojas, Ing. Civil Eléctrico, Ingeniería Eléctrica

- Malcolm Moreno, Administrador REDECA-BNI-SCIAN-Lab



- Dra Karina Palma, PostDoc SCIAN/LEO-Lab



- Dra Carmen Lemus, Bióloga, PostDoc SCIAN/LEO



- MSc(c) Nicole Canales, T. Médico, SCIAN, Microbiología



- Dante Castagnini, SCIAN-Lab, Bioquímico



- Martín Cádiz, Ing. Civil SCIAN-Lab, Eléctrico

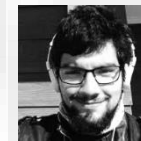

- Dr Camilo Sotomayor, Medico, SCIAN/HCUCH-Lab



Este equipo humano avanzado conforma actualmente BioMat-LEO/SCIAN/BNI.

Busca apoyar a científicos y colaboradores para desarrollar, aplicar, capacitar, y entregar acceso a servicios de metodologías cuantitativas con microscopía de avanzada, procesamiento de imágenes, diseño 3D, y manejo de datos masivos.





Children
Hospital

Institute of
Biomedical Sciences

Nacional Cancer Institute

Faculty of Medicine

Public
Health
Institute

University Hospital & Telemedicine

Psychiatric
Clínica

Faculty of Biochemistry & Farmacy
Faculty of Odontology

Psychiatric
Hospital

Children
Hospital

Institute of
Biomedical

Nacional Cancer Institute

Faculty of M



Public
Health
Institute

University Hospital & Telemedicine

Psychiatric
Clínica

Faculty of Biochemistry & Farmacy
Faculty of Odontology

Psychiatric
Hospital

Tecnologías de bioimaging existentes en el país.



FONDEQUIP ...

~40 microscopios ópticos y electrónicos con financiamiento estatal FONDEQUIP (2011 →)

https://servicios.conicyt.cl/buscadorequipos/#/search_result/microscopio

La Red de Equipamiento Científico Avanzado: <https://redeca.med.uchile.cl>

Santiago y universidades e institutos públicos/privados concentran la mayor cantidad de equipamiento

- 10 microscopios @ REDECA (F-Med, U. de Chile)
- 7 entre CEMC y otras facultades (F-Med, U. de Chile)
- 6 microscopios ópticos y 2 TEM 2 SEM a @ PUC
- 9 microscopios @ CMA Bio Bio (U. Concepción)
- ...

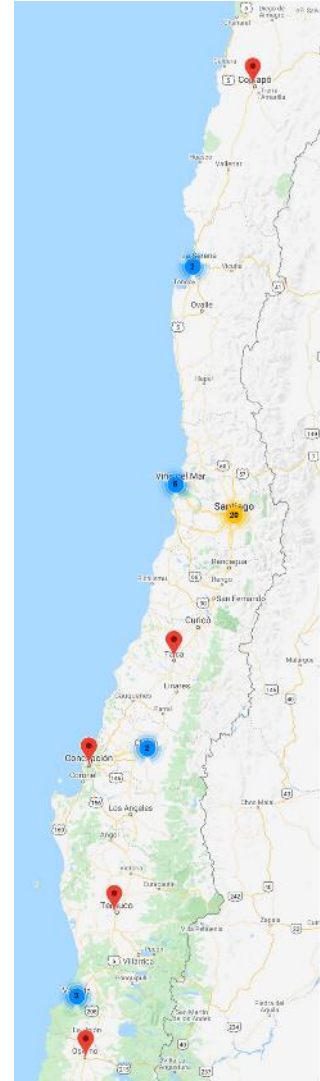

1st LATIN AMERICA BIOIMAGING MEETING

“International Cooperation for Building Bioimaging Capacities in Latin America”

Hybrid Meeting
September 12th - 13th, 2022
Montevideo, Uruguay

- Registration Open & Free
Deadline: August 22nd
- Travel Grants Available!!!
Deadline: August 8th

- ### Satellite Events
- Exchange of Experience VII
 - Imaging Latin America



Organized by



Financed by



The international network of cutting-edge bioimaging facilities and communities



Exchange of
Experience



Training



Shadowing

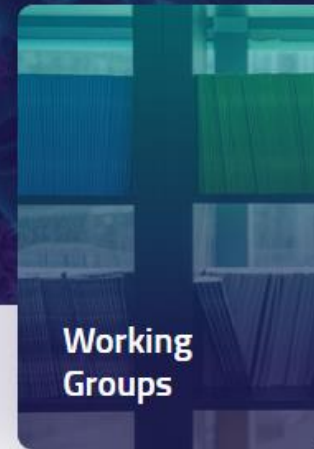

Working
Groups

Organización de la oferta nacional de training/educación/divulgación.

Talleres, Cursos de postgrado, Summer Schools anuales.

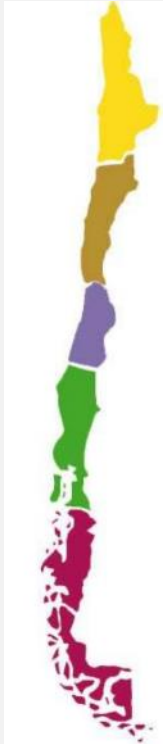

Malla de Módulos y Cursos

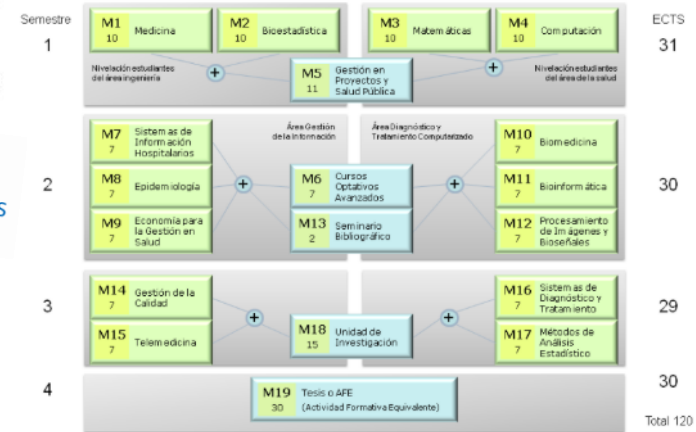

<https://www.latambioimaging.org>

<https://www.youtube.com/channel/UCbJbH590dYWqgmtn-0Malug/videos>

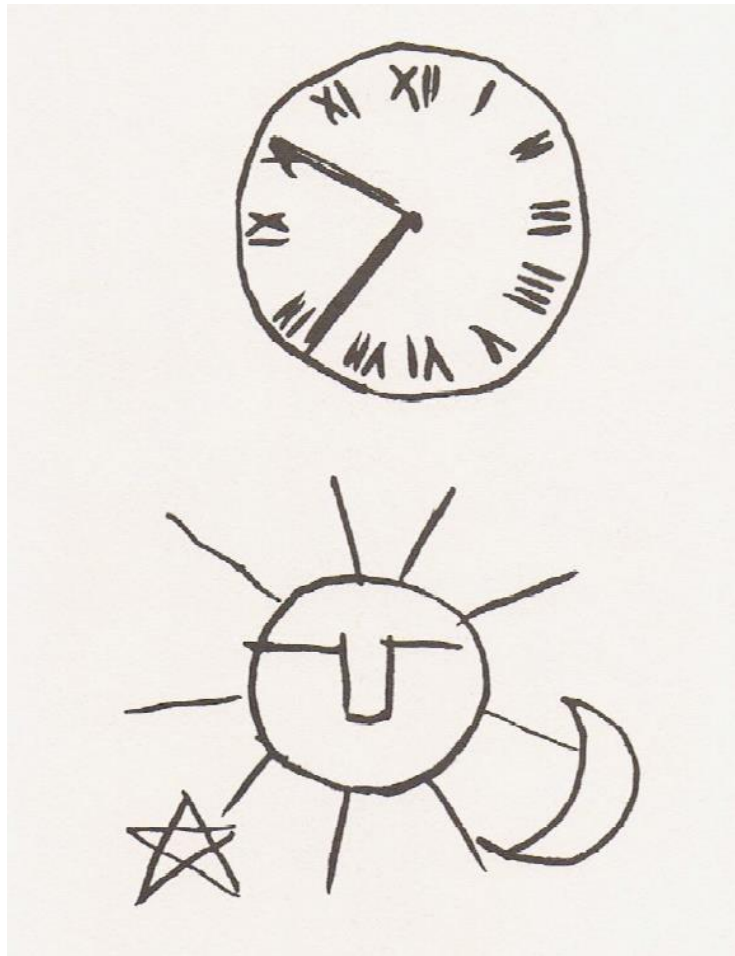

PENSAR ES GEOMETRIZAR

La geometría es como un teclado de lenguajes ...

... curvas, regulares o no, rectas, ángulos, circunferencias, arcos ...

... son los pocos elementos universales con que se puede expresar todo !!!!

Joaquín Torres García

Uruguayo, pintor y pensador,

Montevideo, Barcelona, París, NY ...

morfología

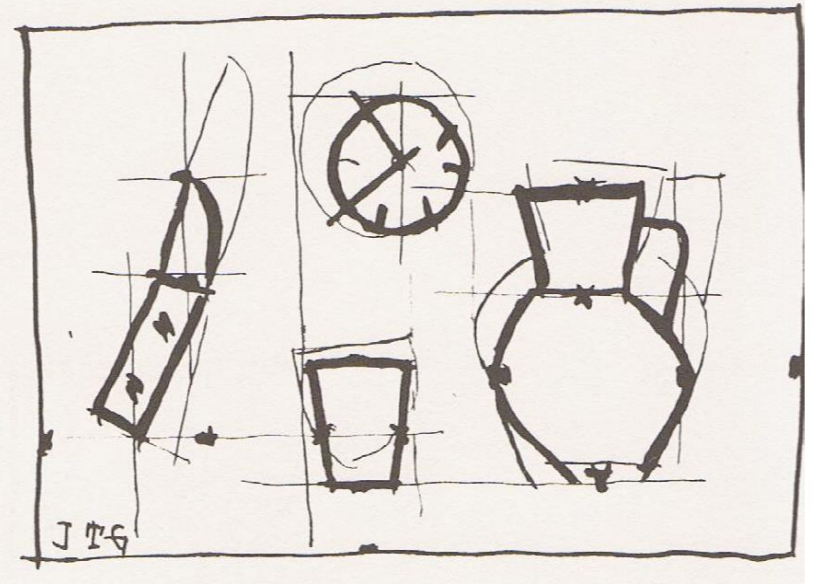

topología



tiempo

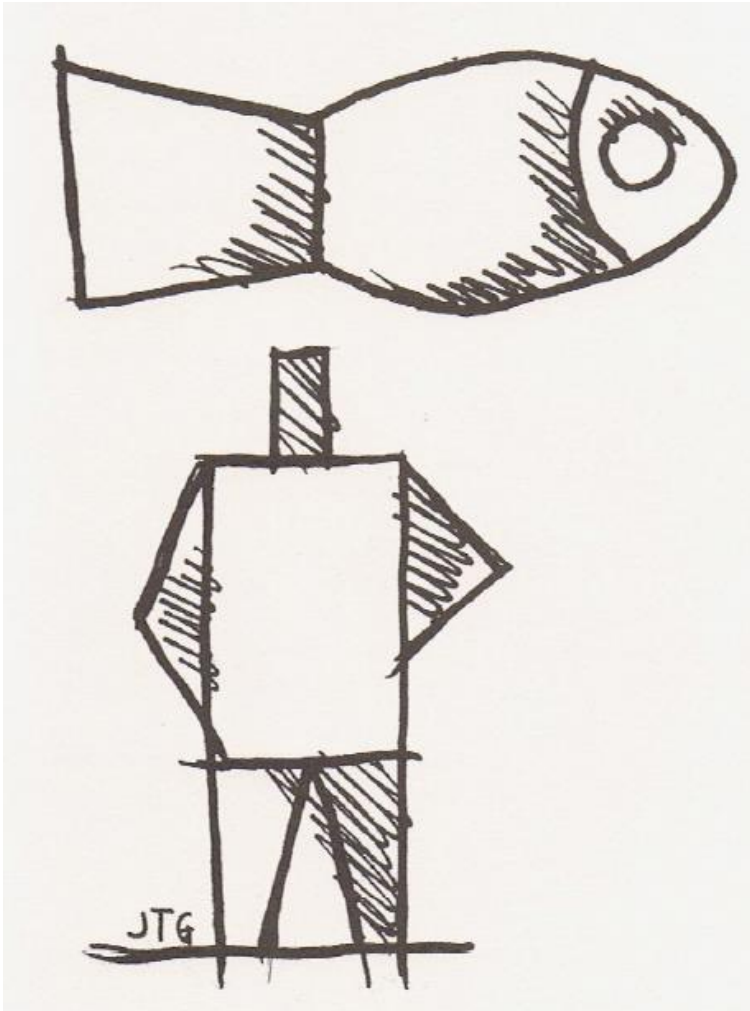
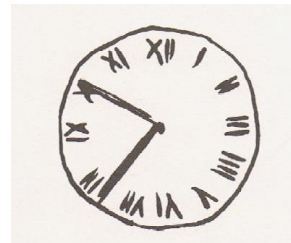

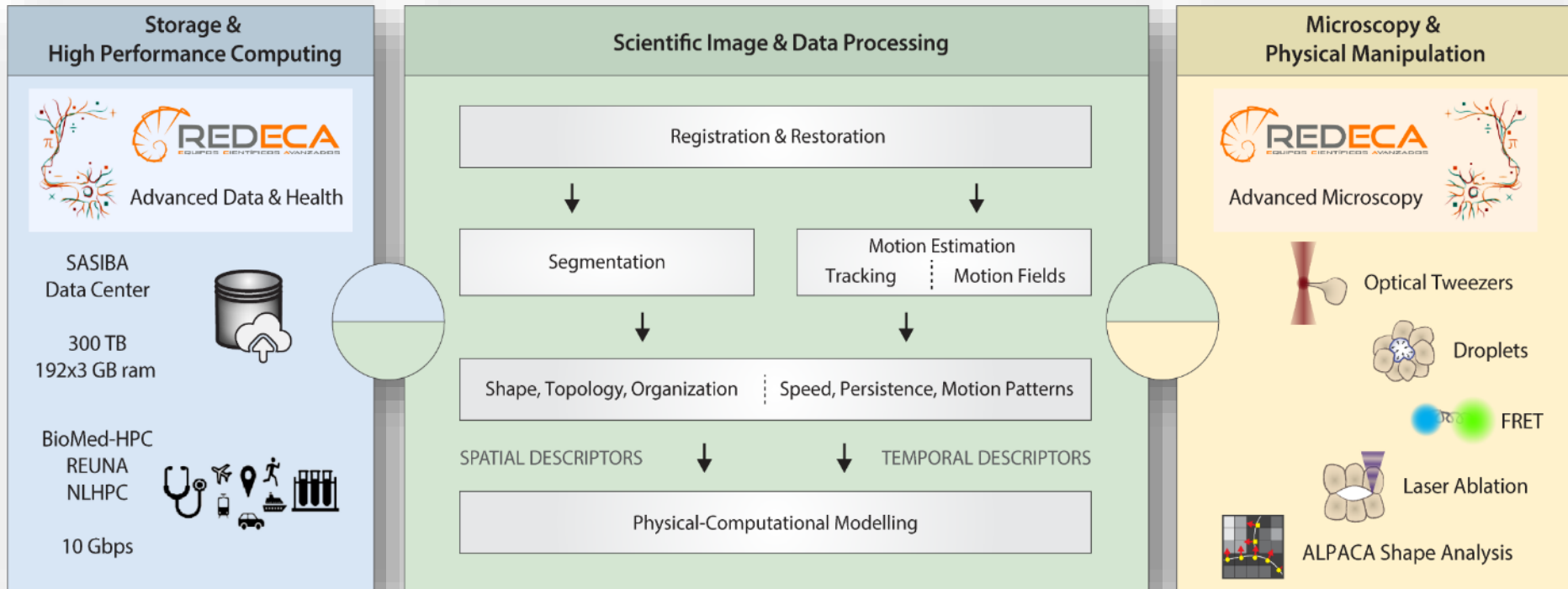

**UNIVERSALISMO
CONSTRUCTIVO**



[nature](#) > [nature methods](#) > [comment](#) > [article](#)

Comment | [Published: 04 May 2021](#)

A global view of standards for open image data formats and repositories

[Jason R. Swedlow](#) , [Pasi Kankaanpää](#), [Ugis Sarkans](#), [Wojtek Goscinski](#), [Graham Galloway](#), [Leonel Malacrida](#), [Ryan P. Sullivan](#), [Steffen Härtel](#), [Claire M. Brown](#), [Christopher Wood](#), [Antje Keppler](#), [Federica Paina](#), [Ben Loos](#), [Sara Zullino](#), [Dario Livio Longo](#), [Silvio Aime](#) & [Shuichi Onami](#) 

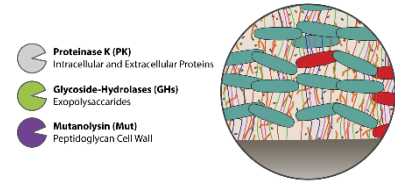
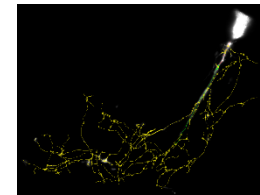
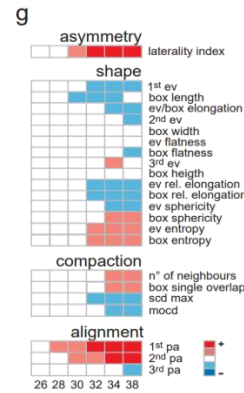
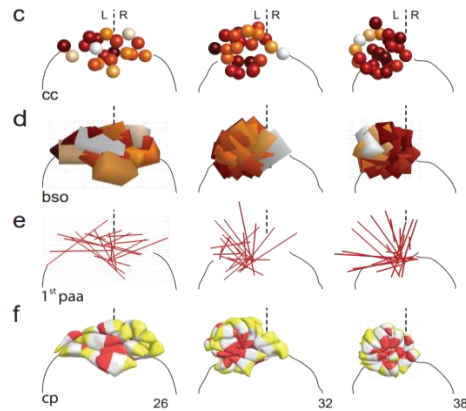
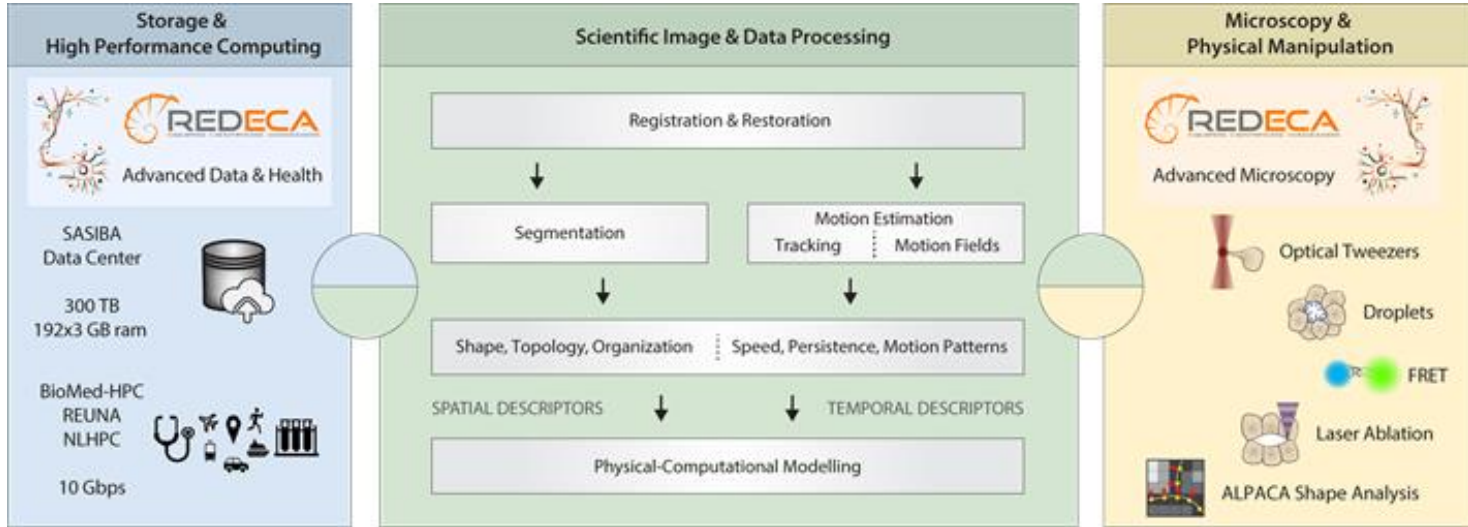

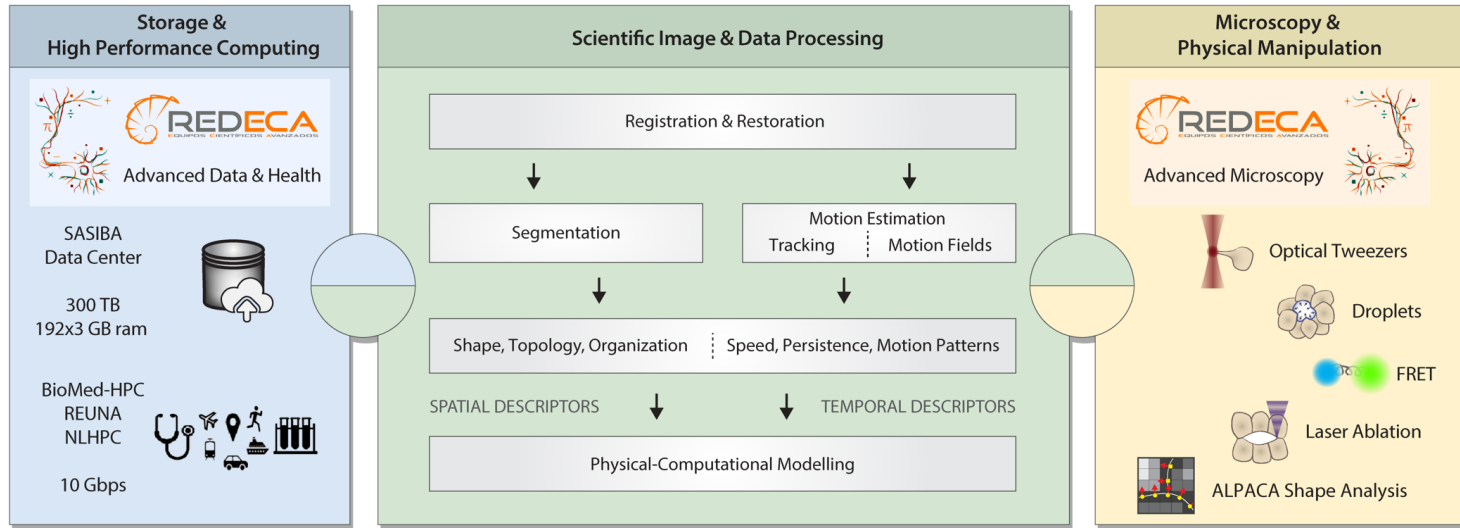

GLOBAL BIOIMAGING
growing collaboration

- Exchange of experience
- Training
- Shadowing
- Document Galleries

A Global View of Standards for Open Image Data Formats and Repositories.
Nature Methods, 2021
Swedlow Jason et al

Architecture for a Distributed Medical Image Network

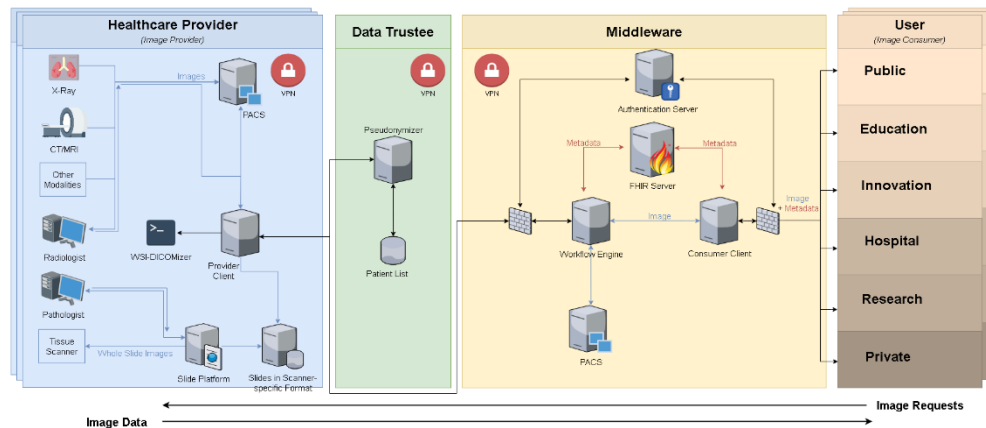

¿En qué se aplica la IA? · Visión Computacional

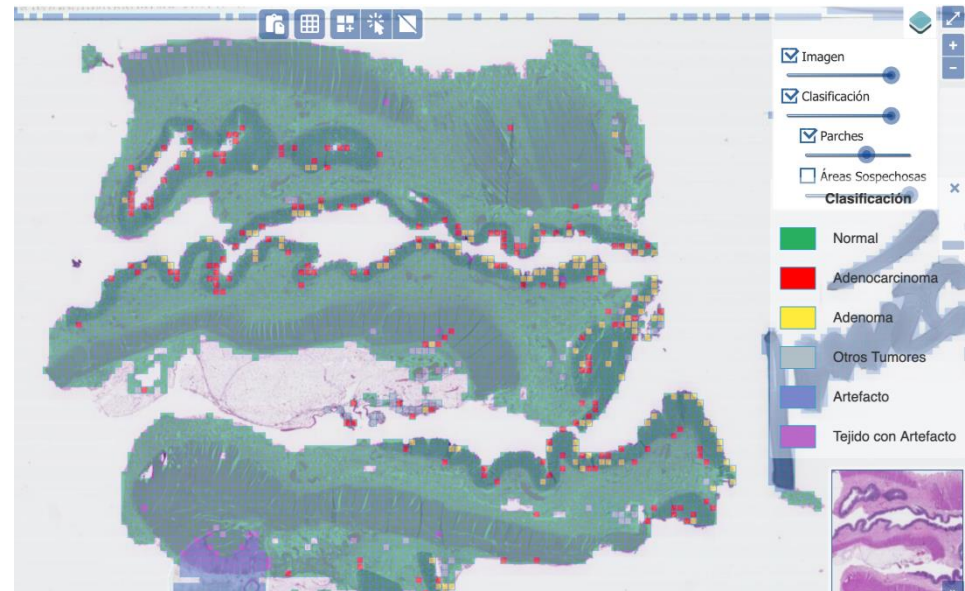
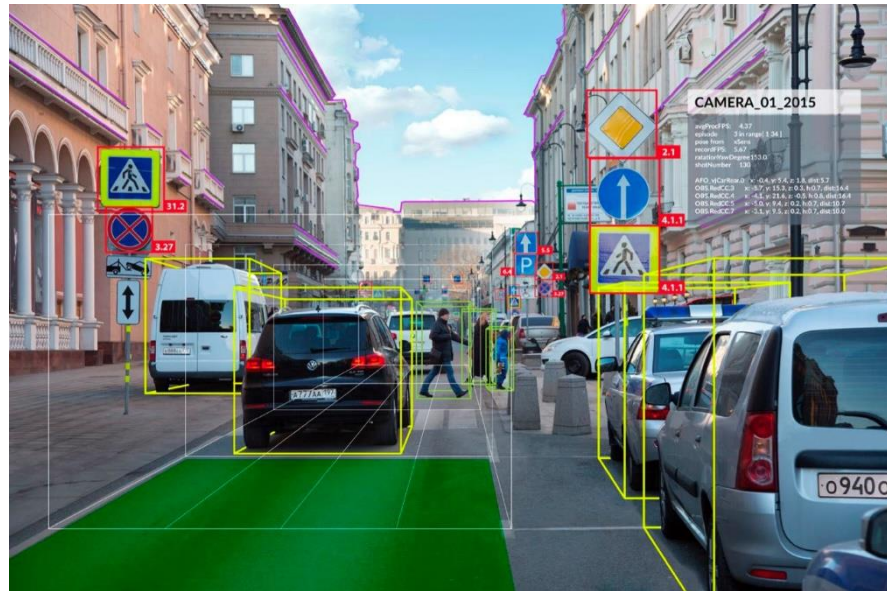



STCMED



HOSPITAL CLÍNICO
UNIVERSIDAD DE CHILE



Proyecto ID19I10334, Concurso IDEa I+D 2019

DeepPathology : Plataforma de TelePatología Distribuida Basada en *Blockchain* y Diagnóstico Colaborativo Apoyado por *Deep Learning*

2020-2021 ANID COVID0733: Härtel S, Cabrera G, CIMT, HCUCH, UdeC
IA-TRAD CHILE: Inteligencia Artificial para apoyo diagnóstico y procesos de atención en radiología y tele-radiología clínica

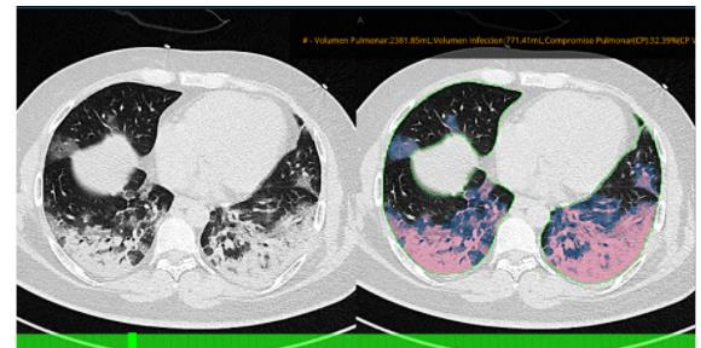
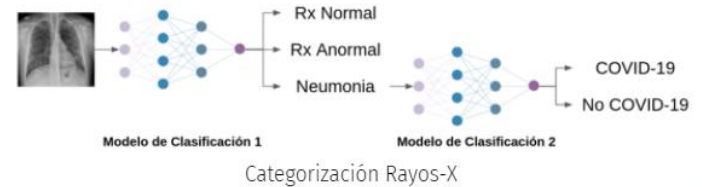
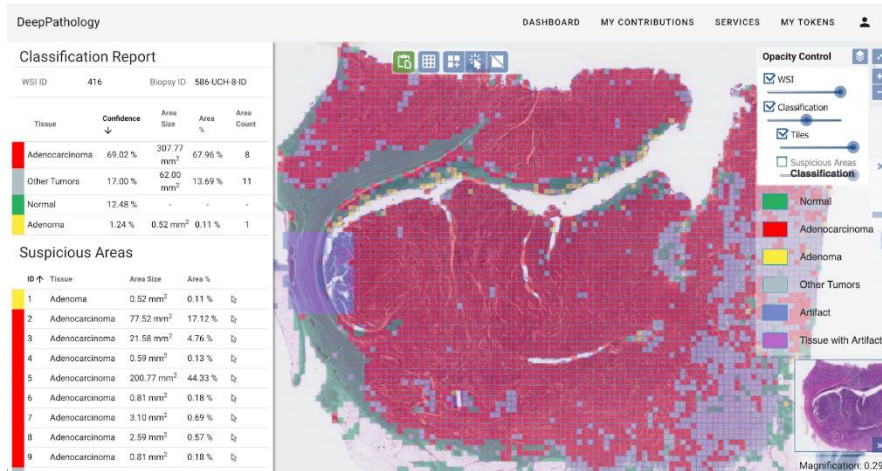

Heidelberg Collaboratory



for Image Processing

University->Faculty of Mathematics and Computer Science->HCI
University->Faculty of Physics and Astronomy->HCI
University->IWR->HCI

- Computer Vision (Ommer lab)
- Digital Image Processing (Jähne lab)
- Image and Pattern Analysis (Schnörr lab)
- Image Processing and Modelling (Garbe lab)
- Multidimensional Image Processing (Hamprecht lab)

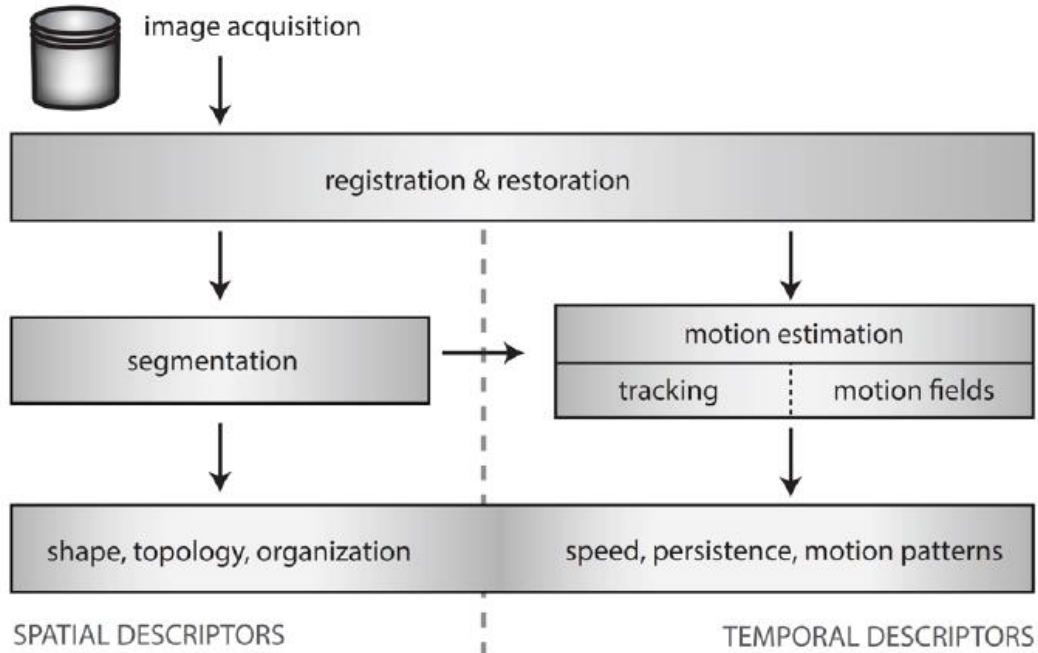

V Castañeda, M Cerda, F Santibáñez, J Jara, E Pulgar, K Palma, ...
[Computational methods for analysis of dynamic events in cell migration](#),
Current molecular medicine 14 (2), 291-307

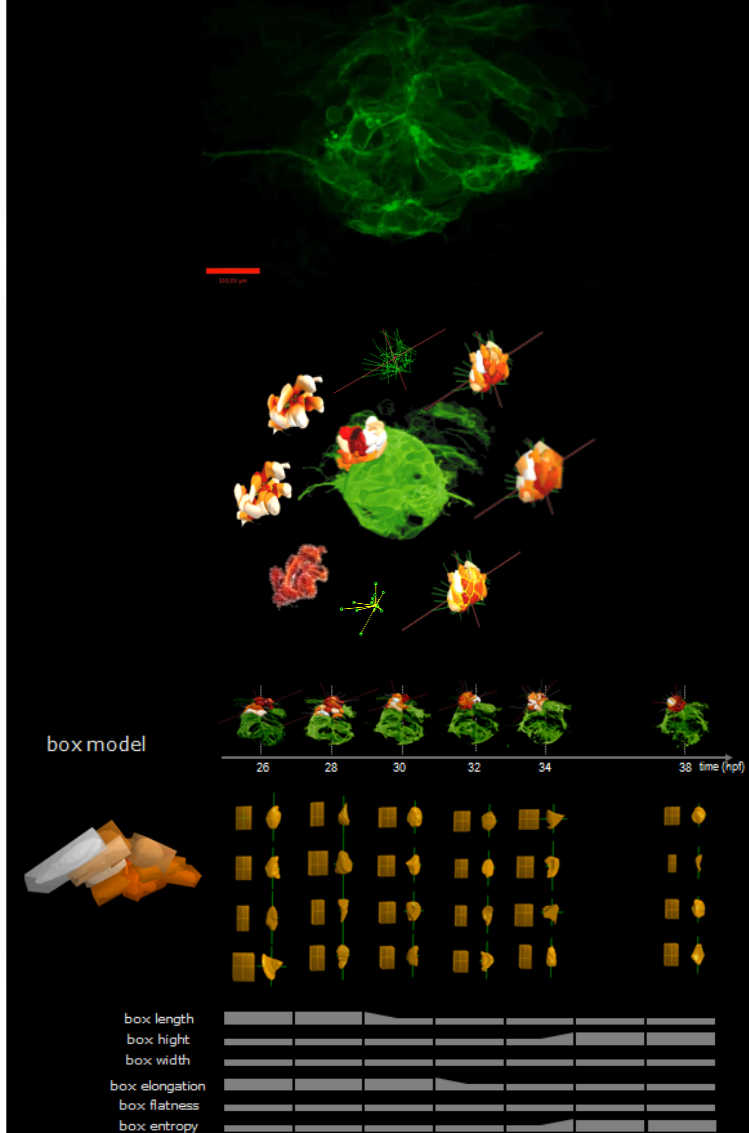

Miguel Concha

Biología del Desarrollo

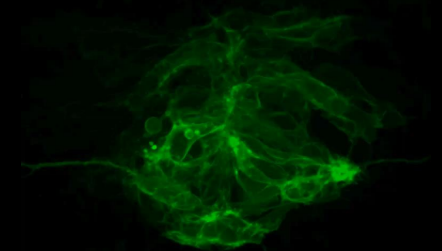
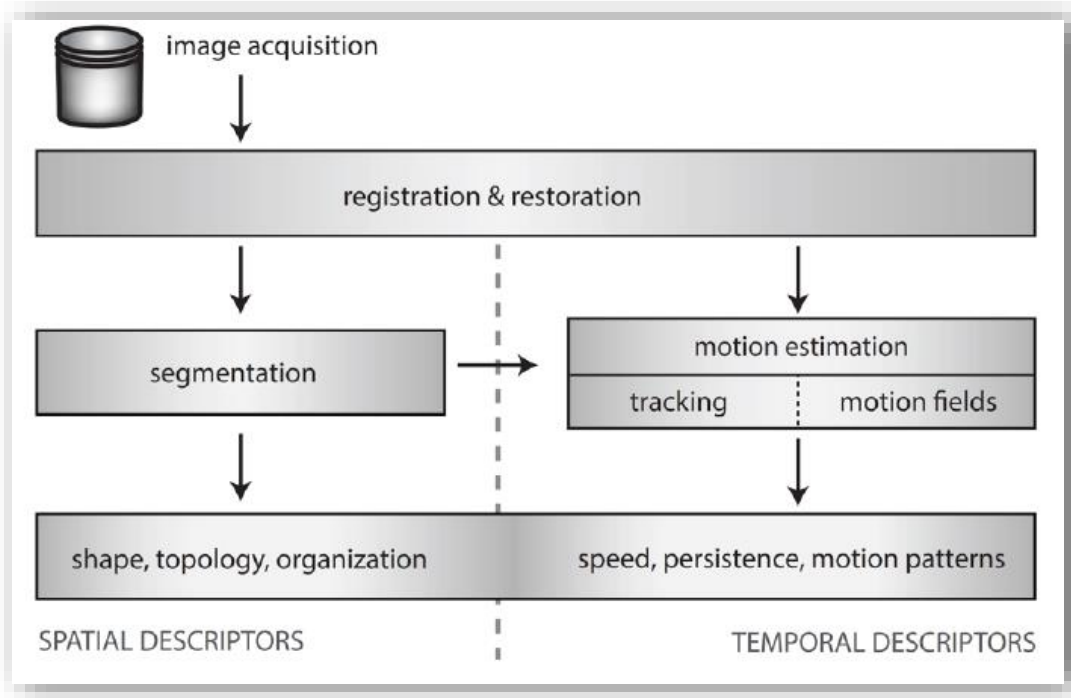
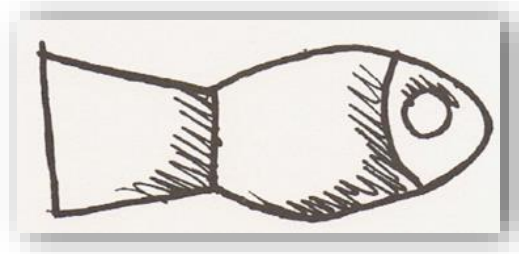

1000 μm



5D *in vivo* Microscopy — Image Processing — Modelling

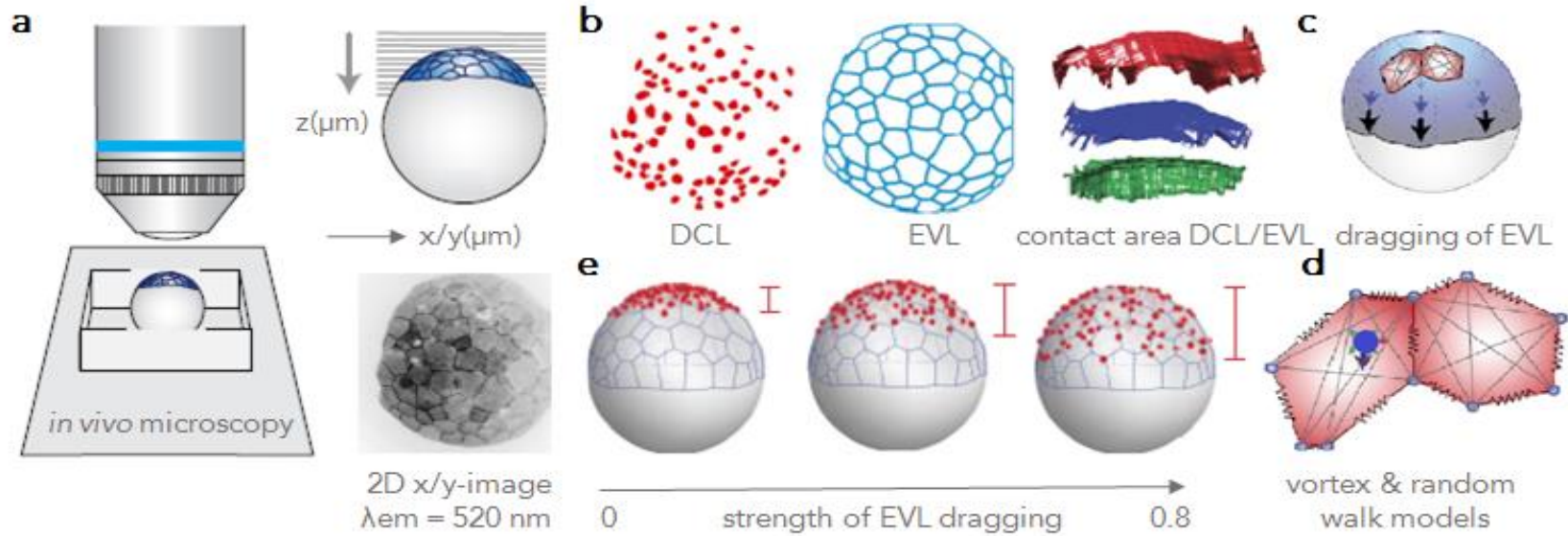

Hypothesis Testing

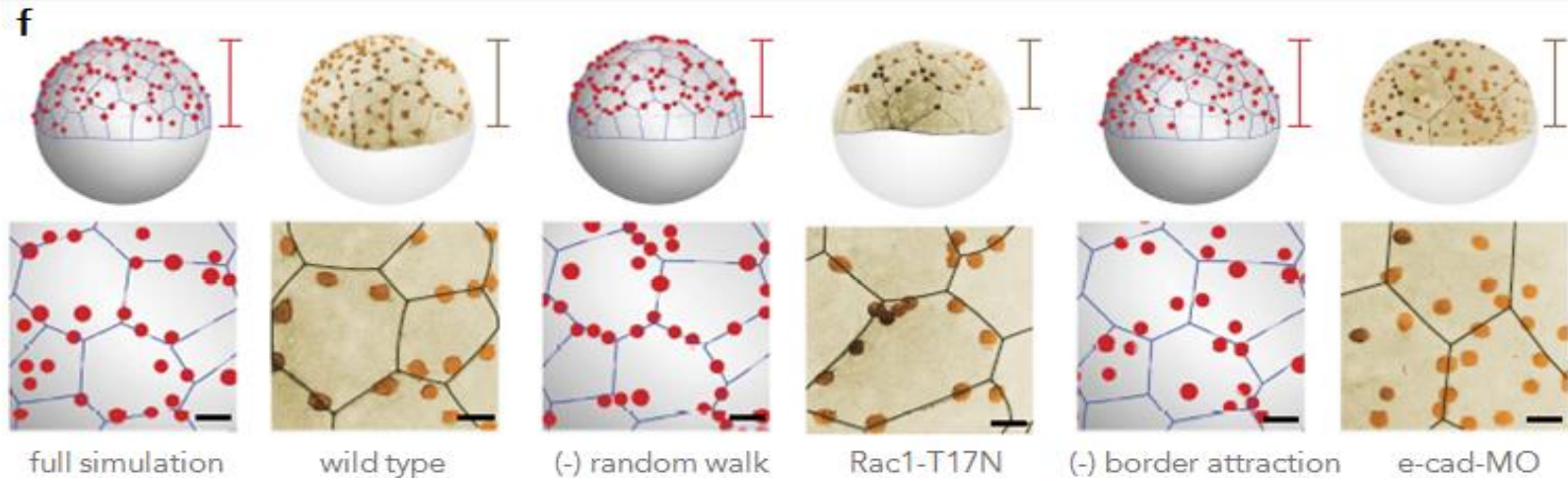

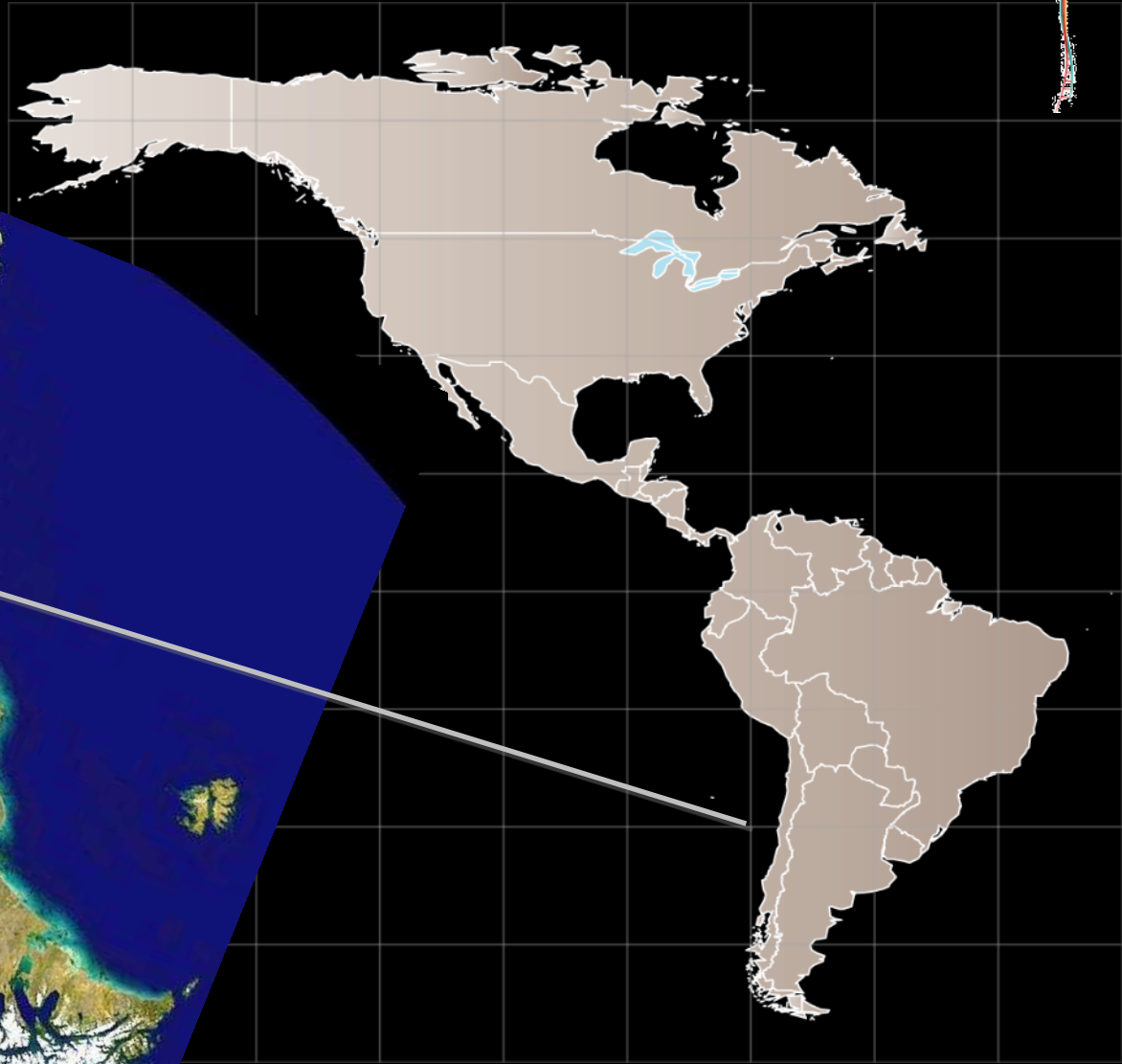

NASA World Wind screenshot.



Very Large Telescope (VLT),
4 Telescopes, 8m, 2600 m



Atacama Large Millimeter/submillimeter
Array (ALMA), 66 Antenna, 5000 m

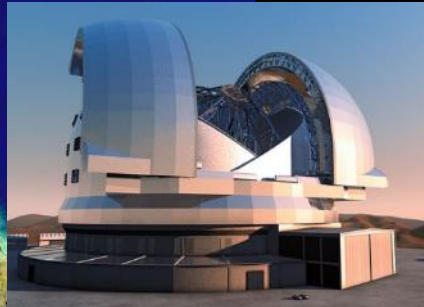

E-ELT European
Extremely Large
Telescope, 39 m, 3000 m

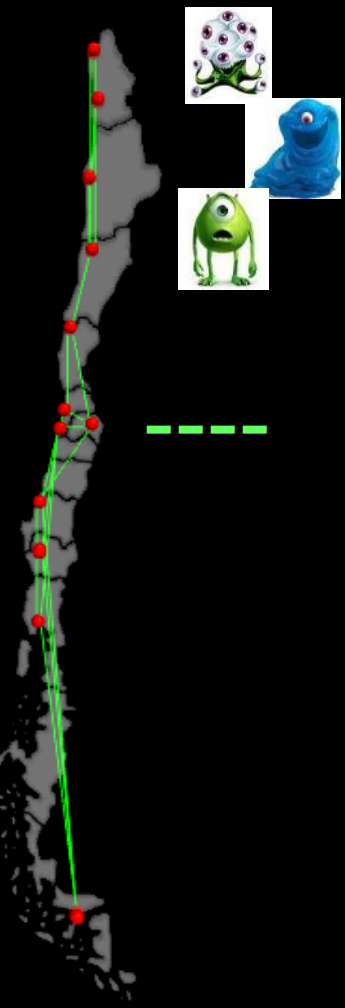
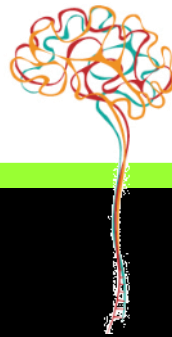

Extraterrestrial Monster Science produces: TeraB, PetaB, ExaB, ZettaB, YottaB

... Tera is a unit prefix in the metric system denoting multiplication by 10^{12} or 1.000.000.000.000 !

... Tera is derived from Greek τέρας (teras), meaning "monster".

... Tera was confirmed for use in the SI in 1960.... Wiki !

Metric prefixes						
Prefix	Symbol	1000 ^m	10 ⁿ	Decimal	English word ^[n 1]	Since ^[n 2]
yotta	Y	1000 ⁸	10 ²⁴	1 000 000 000 000 000 000 000 000	septillion	1991
zetta	Z	1000 ⁷	10 ²¹	1 000 000 000 000 000 000 000	sextillion	1991
exa	E	1000 ⁶	10 ¹⁸	1 000 000 000 000 000 000	quintillion	1975
peta	P	1000 ⁵	10 ¹⁵	1 000 000 000 000 000	quadrillion	1975
tera	T	1000 ⁴	10 ¹²	1 000 000 000 000	trillion	1960
giga	G	1000 ³	10 ⁹	1 000 000 000	billion	1960
mega	M	1000 ²	10 ⁶	1 000 000	million	1960
kilo	k	1000 ¹	10 ³	1 000	thousand	1795
hecto	h	1000 ^{2/3}	10 ²	100	hundred	1795
deca	da	1000 ^{1/3}	10 ¹	10	ten	1795
		1000 ⁰	10 ⁰	1	one	–
deci	d	1000 ^{-1/3}	10 ⁻¹	0.1	tenth	1795
centi	c	1000 ^{-2/3}	10 ⁻²	0.01	hundredth	1795
milli	m	1000 ⁻¹	10 ⁻³	0.001	thousandth	1795
micro	μ	1000 ⁻²	10 ⁻⁶	0.000 001	millionth	1960
nano	n	1000 ⁻³	10 ⁻⁹	0.000 000 001	billionth	1960
pico	p	1000 ⁻⁴	10 ⁻¹²	0.000 000 000 001	trillionth	1960
femto	f	1000 ⁻⁵	10 ⁻¹⁵	0.000 000 000 000 001	quadrillionth	1964
atto	a	1000 ⁻⁶	10 ⁻¹⁸	0.000 000 000 000 000 001	quintillionth	1964
zepto	z	1000 ⁻⁷	10 ⁻²¹	0.000 000 000 000 000 000 001	sextillionth	1991
yocto	y	1000 ⁻⁸	10 ⁻²⁴	0.000 000 000 000 000 000 000 001	septillionth	1991

The Scale of the Universe <https://htwins.net/scale2>



The Scale of the Universe <https://htwins.net/scale2>

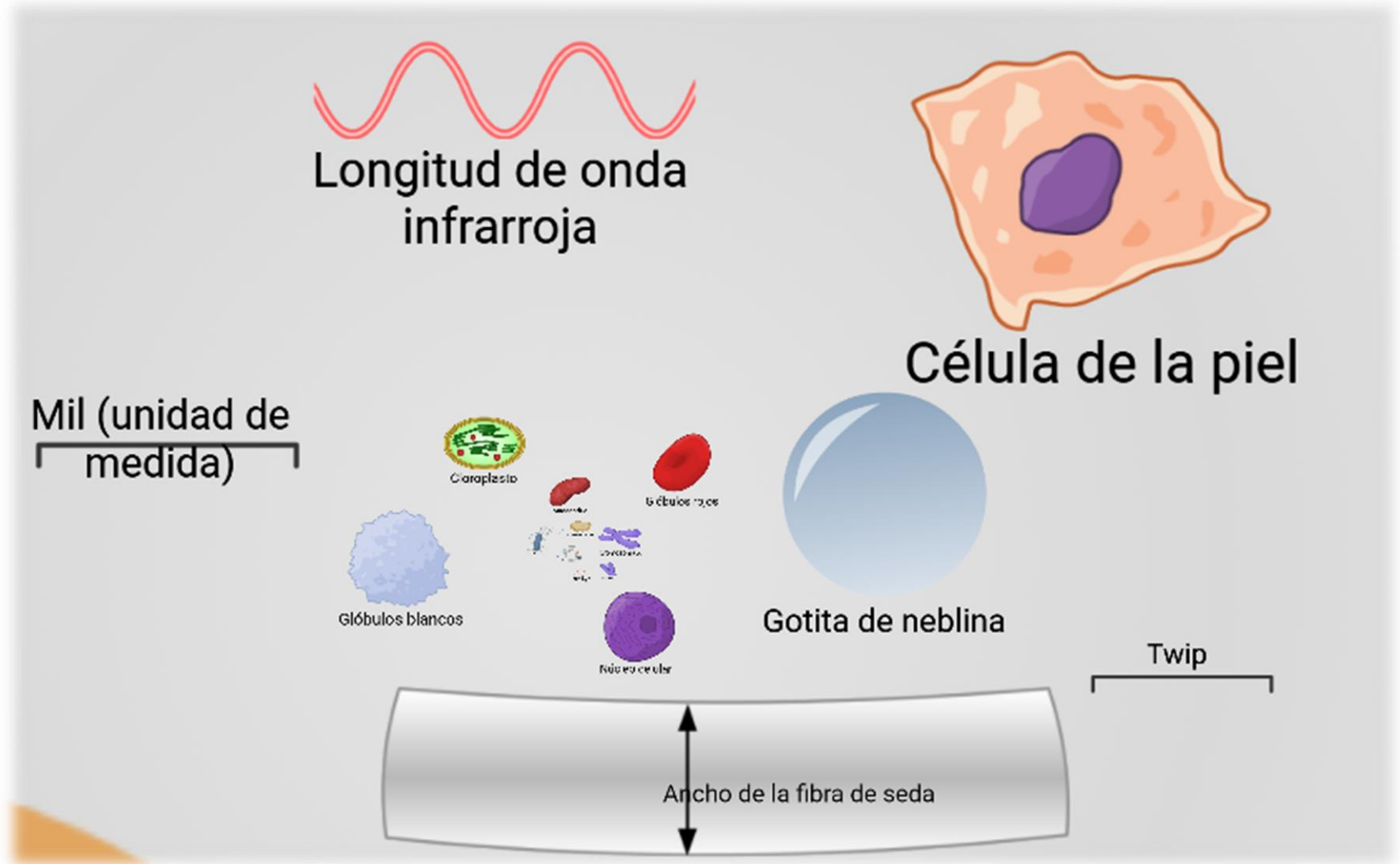

The Scale of the Universe <https://htwins.net/scale2>

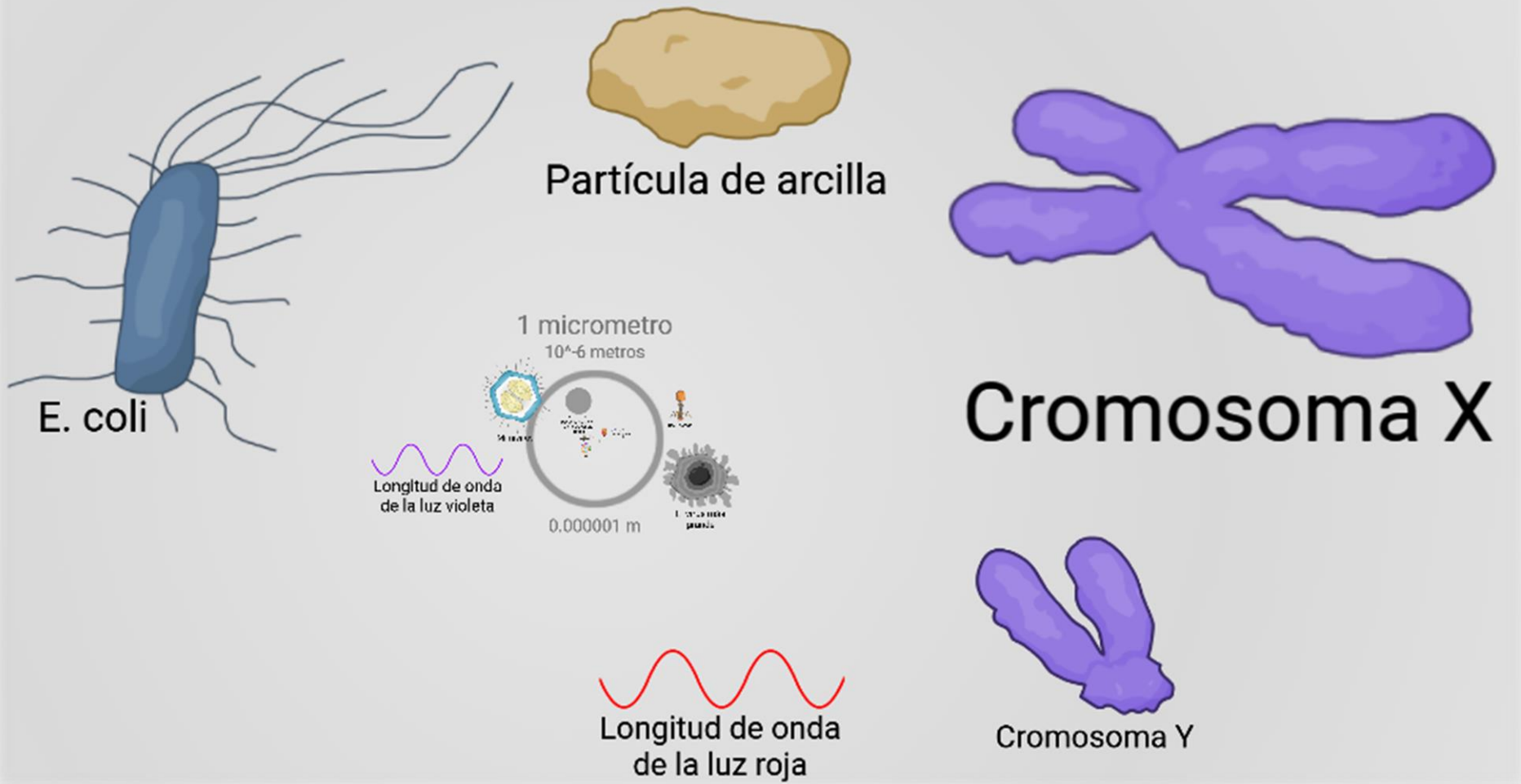

redeca.med.uchile.cl



Inicio

Quienes somos

Unidades de Servicios ▾

Contacto



Bienvenid@s a REDECA

REDECA provee apoyo tecnológico, acceso y acompañamiento en el uso de servicios y equipos avanzados. Usuarios de la institución y externos pueden solicitar asistencia para la selección de servicios o equipos adecuados a sus desafíos experimentales, el almacenamiento y el análisis de sus datos.

¡ REDECA... haz ciencia con nosotros !

|-> Perkin Elmer Spinning Disk with laser ablation

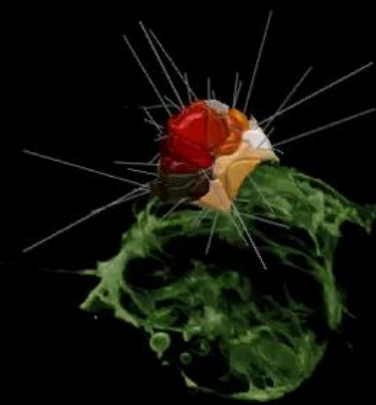
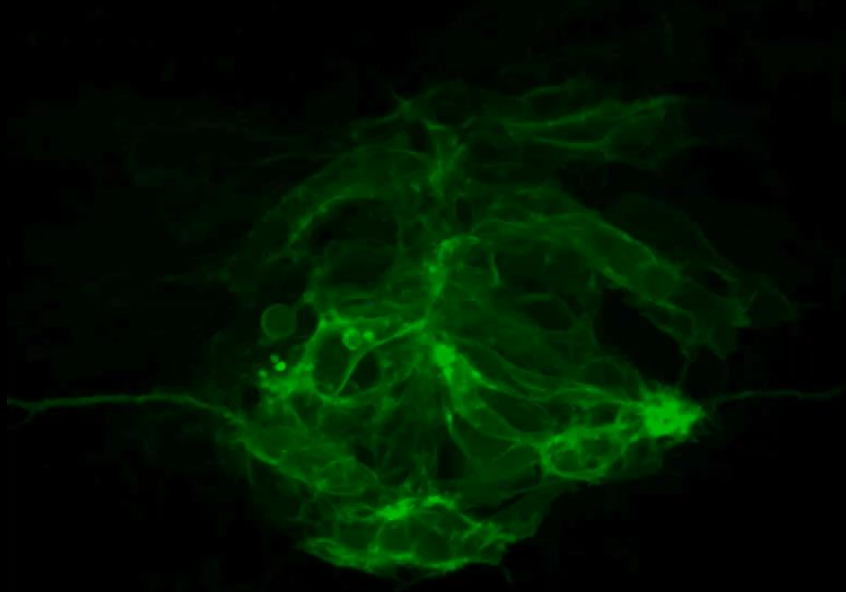
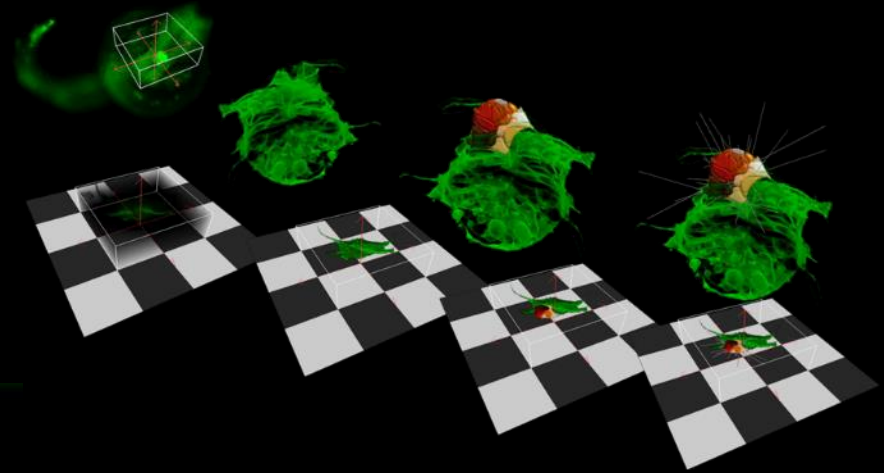

| -> Deconvolution

box model

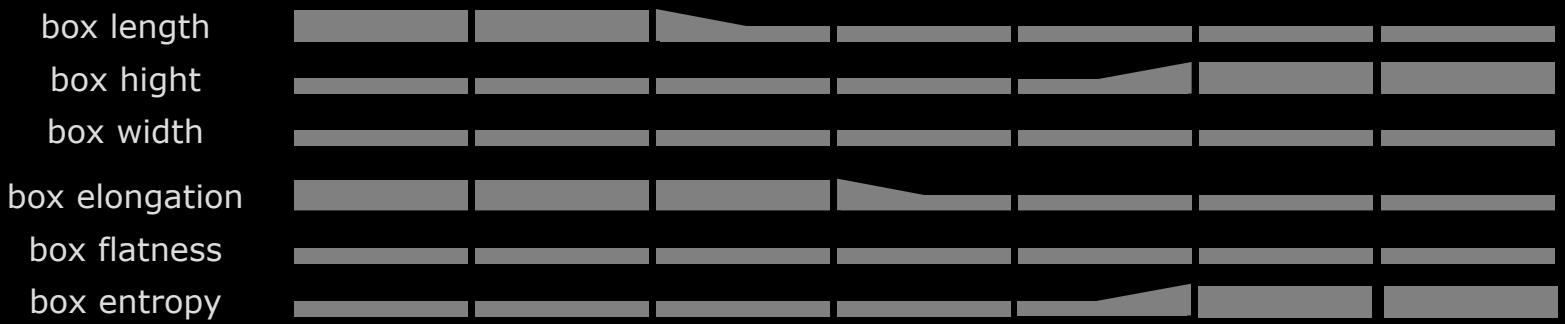
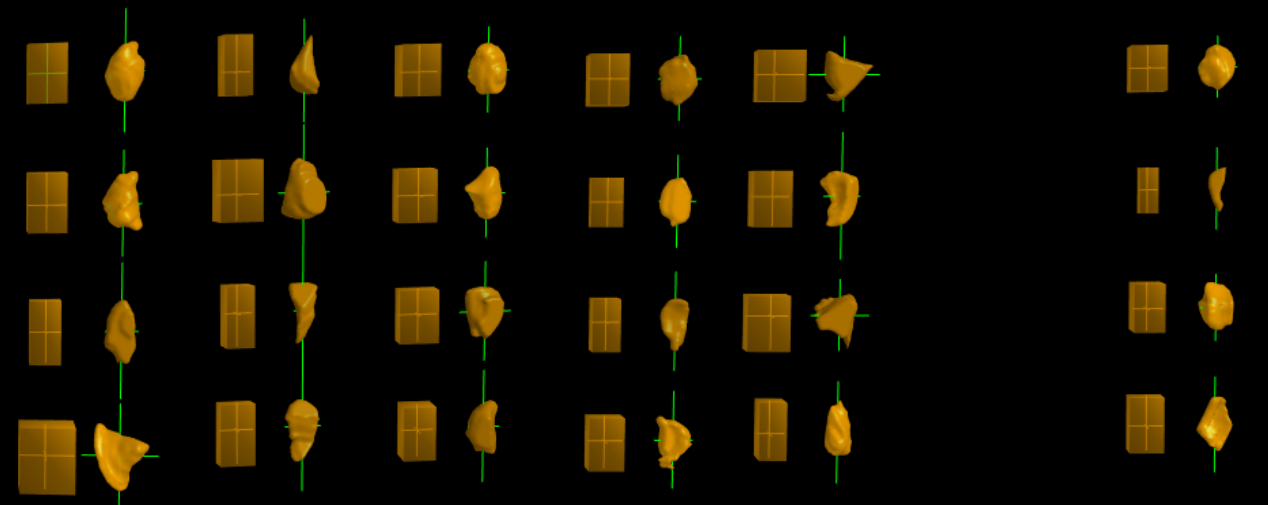
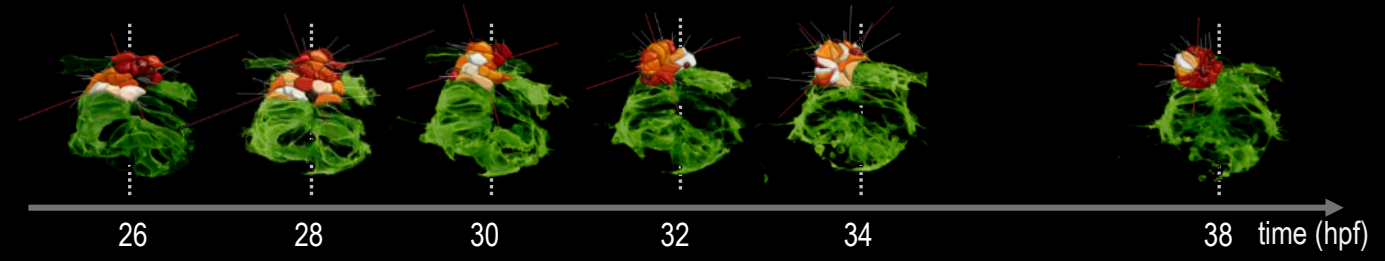

|-> Perkin Elmer Spinning Disk with Micropoint Laser Ablation.



2021 RyR-mediated Ca^{2+} release elicited by neuronal activity induces nuclear Ca^{2+} signals, CREB phosphorylation, and Npas4/RyR2 expression P Lobos, A Córdova, I Vega-Vásquez, OA Ramírez, T Adasme, ... *Proceedings of the National Academy of Sciences* 118 (33)

2021 Ryanodine receptor-mediated Ca^{2+} release and atlastin-2 GTPase activity contribute to IP3-induced dendritic Ca^{2+} signals in primary hippocampal neurons, OA Ramírez, A Córdova, M Cerda, P Lobos, S Härtel, ... *Cell Calcium* 96, 102399

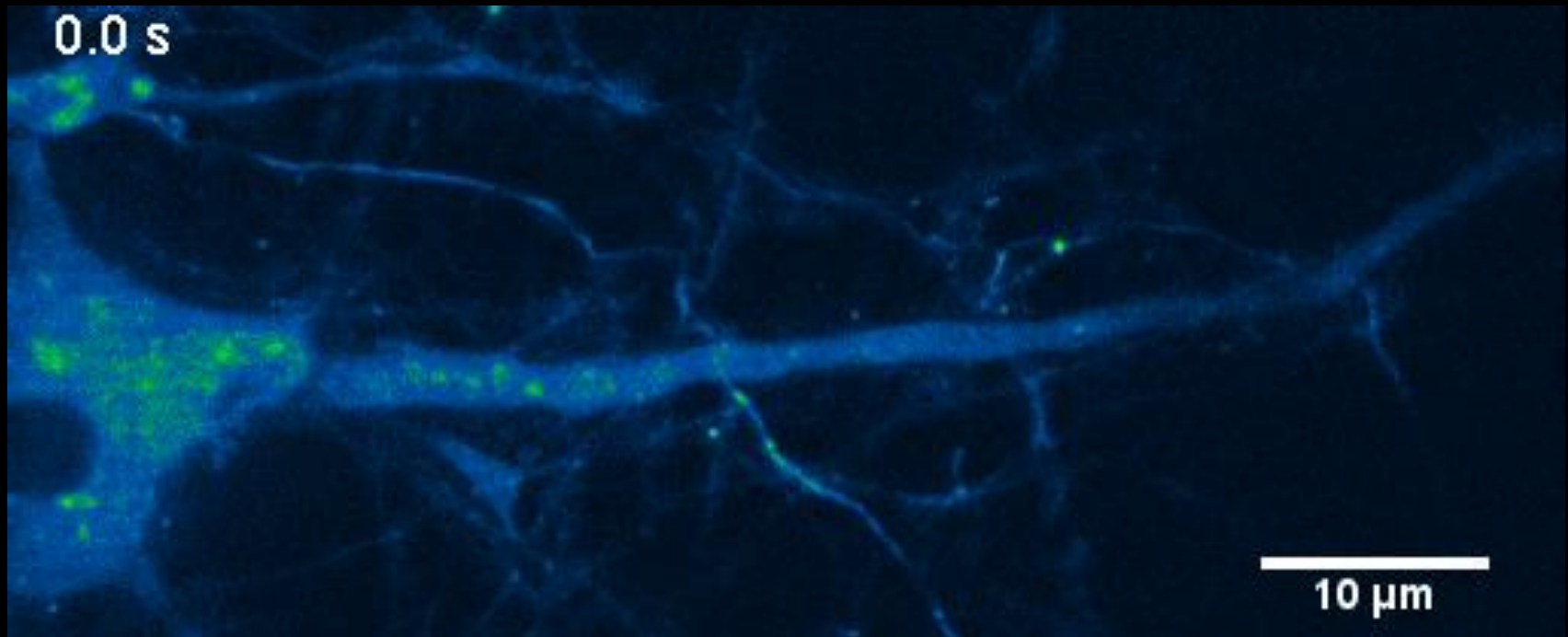

|-> Perkin Elmer Spinning Disk

Austrolevias Nigripinnis, Microinyección mRNA para la expresión de LifeAct-GFP (actina). migración de Deep Cells (DC) a través del Enveolpping Layer (EVL). (G.Reig)

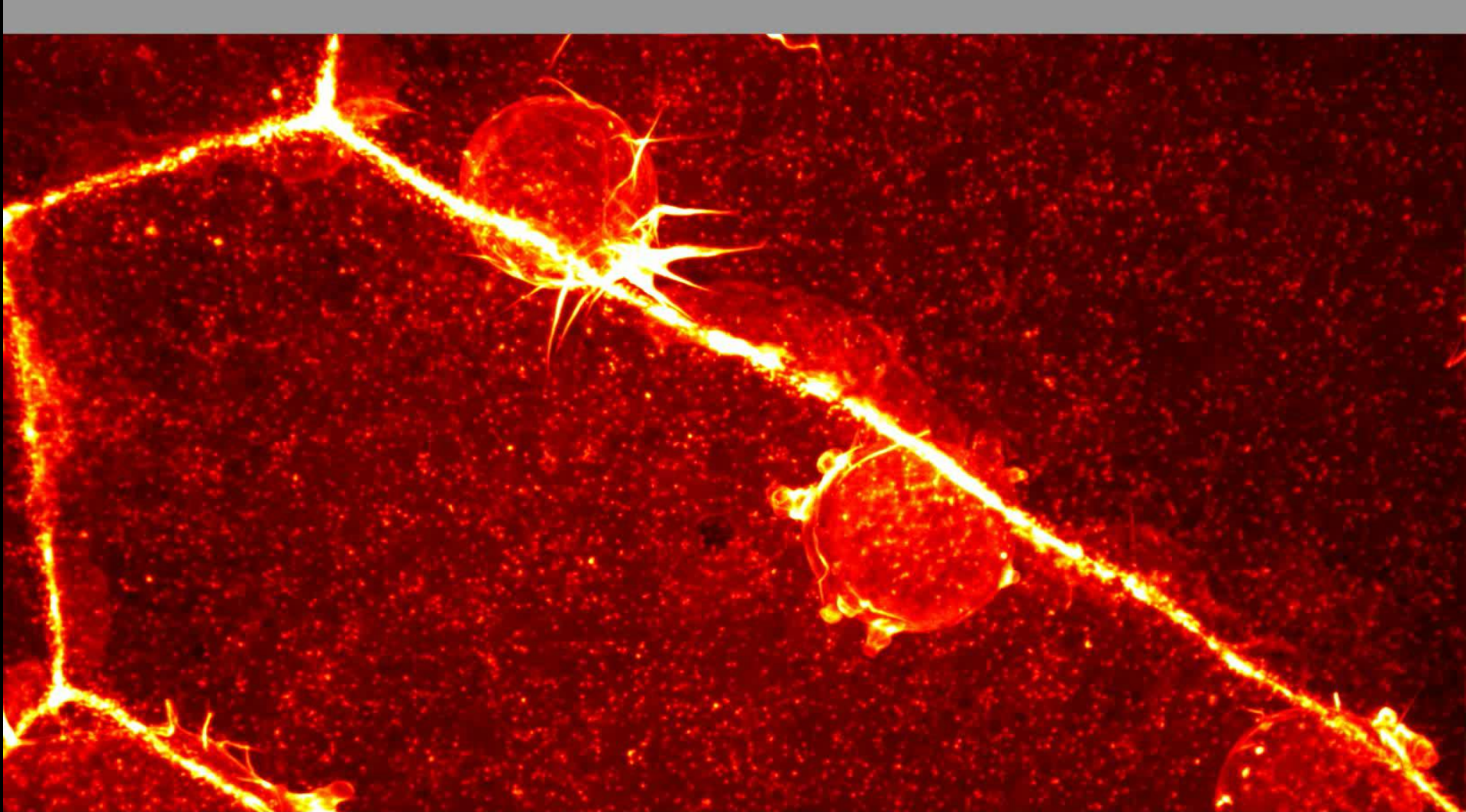



Scian/Leo-Lab: Perkin Elmer Spinning Disk with laser ablation

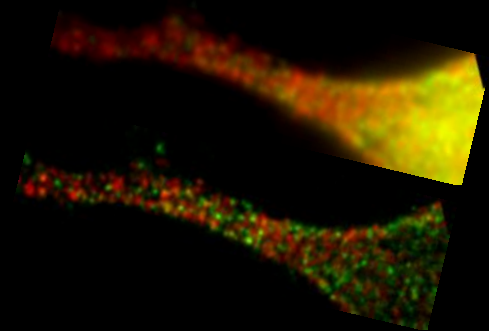
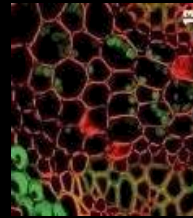
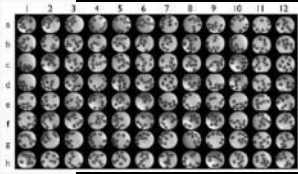
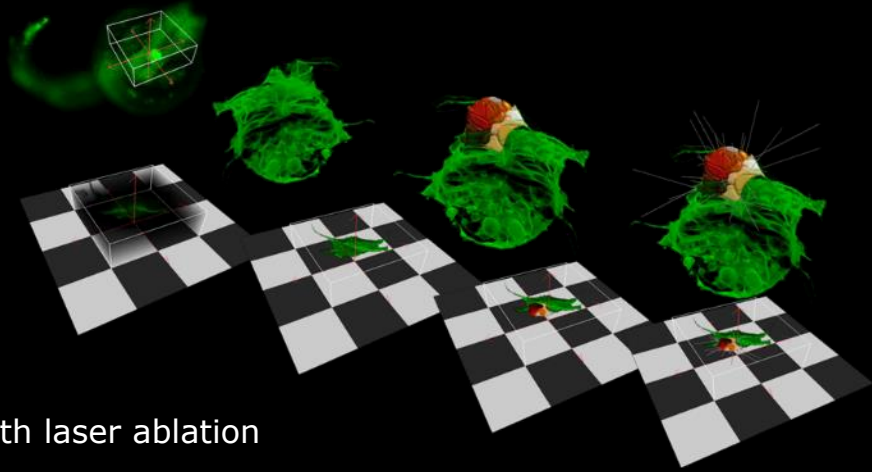

SCIAN-Lab Leica TCS LSI Super Zoom Spectral Confocal + Superresolution Optical Fluctuation Imaging SOFI

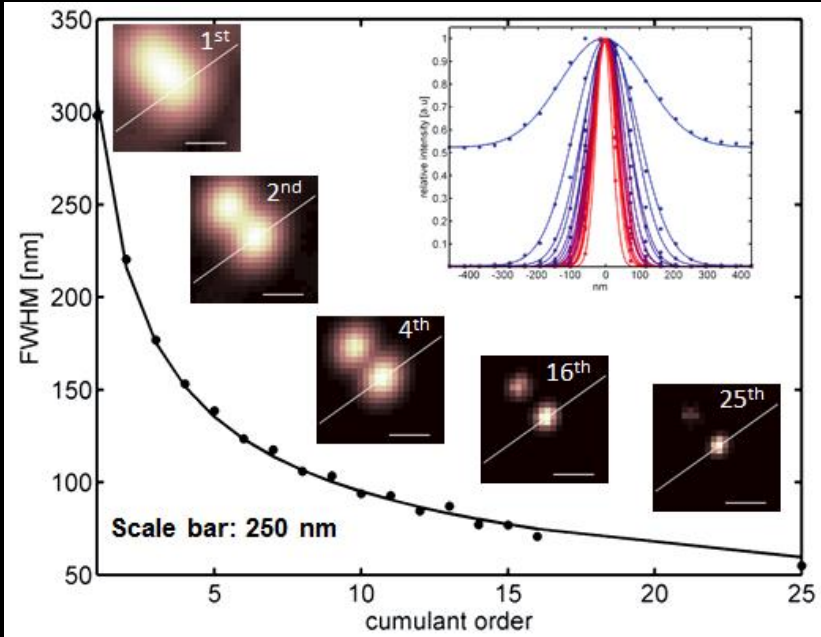

Dertinger et al 2009 PNAS

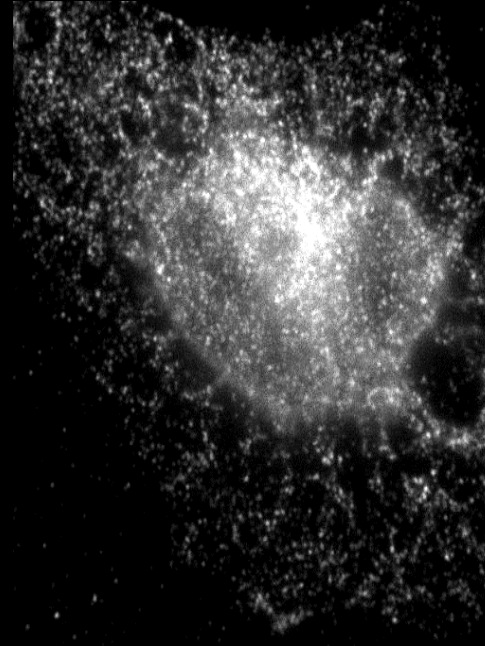

COS7 myc-GABABR1 conjugados con QDots 525 nm

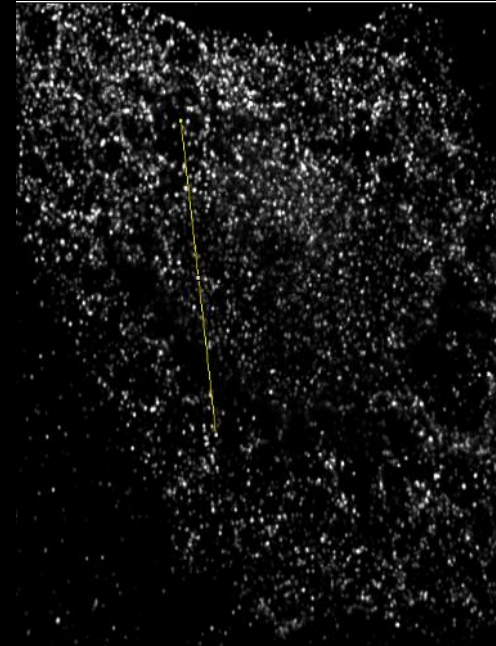

Mayor Challenges:

- vibrations
- computational backbone
- sustainability

Jörg Enderlein
Göttingen

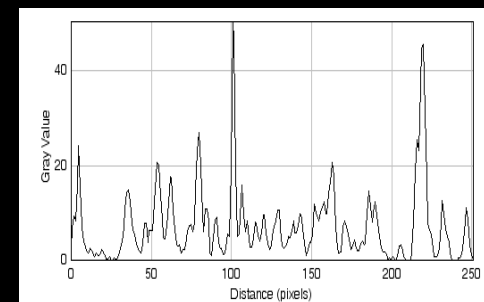
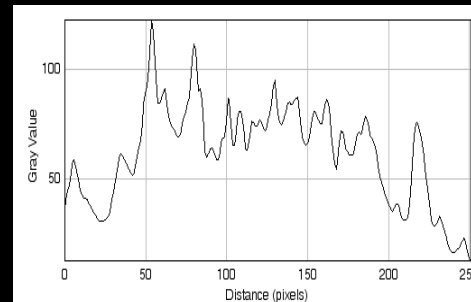



Scian/Leo-Lab: Perkin Elmer Spinning Disk with laser ablation

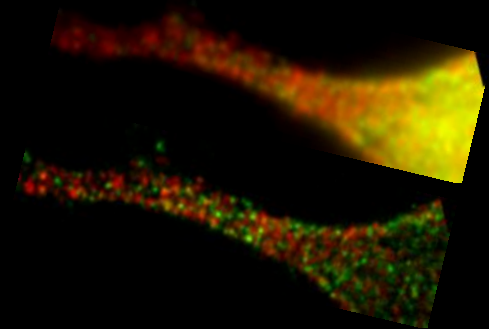
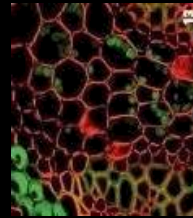
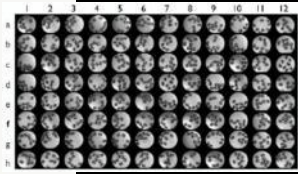
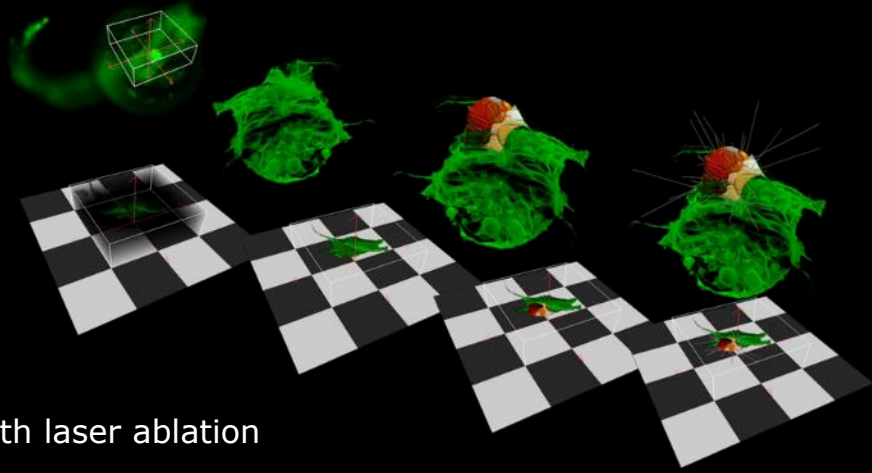

SCIAN-Lab Leica TCS LSI Super Zoom Spectral Confocal + Superresolution Optical Fluctuation Imaging SOFI

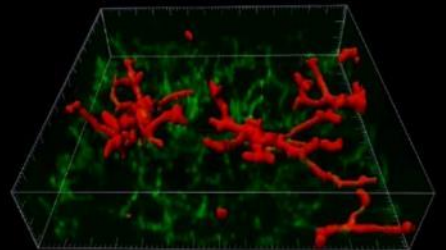
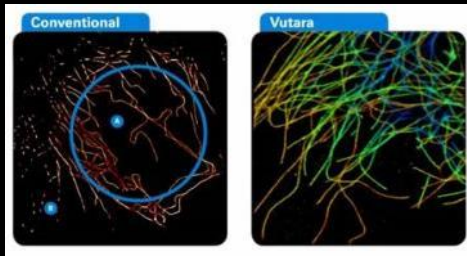

Couve-Lab PALM Vtarar 200, Bliplane 3D

H2B-mCherry

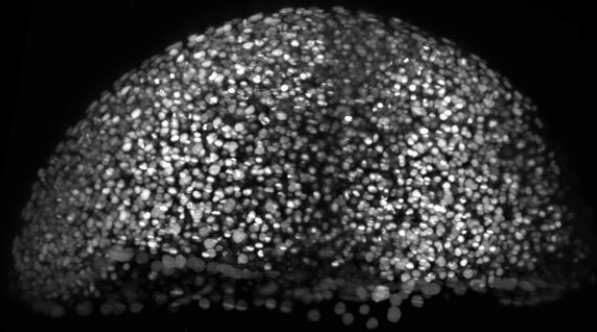

crestin::GFP



merge

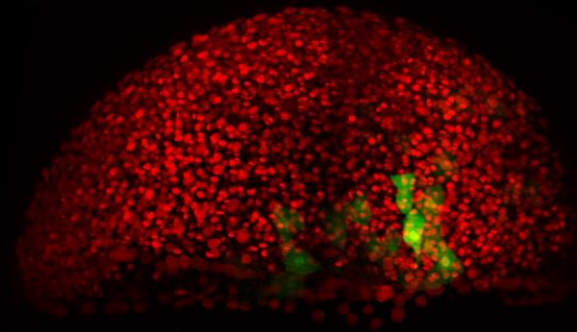

00:00:00

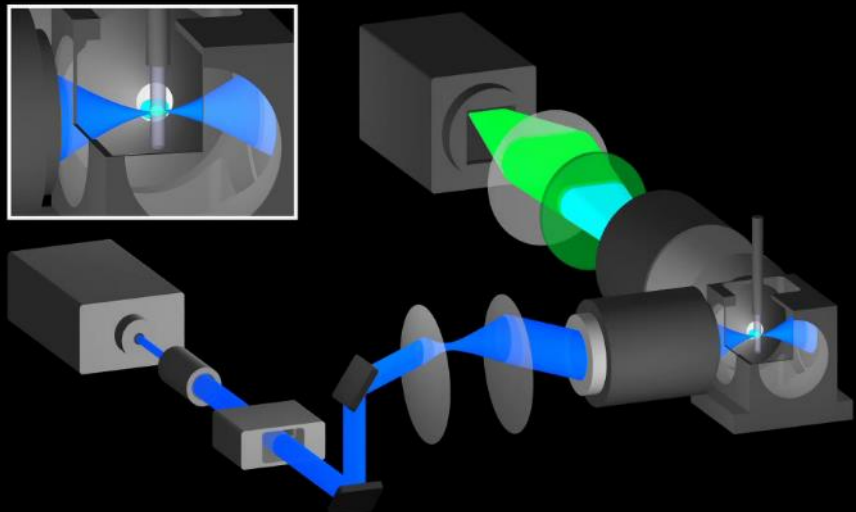
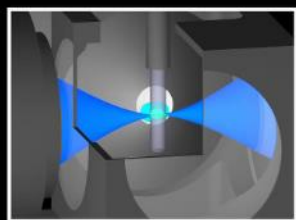

Pulgar, Keller, Concha, unpublished



Ulrich Kubitscheck
Bonn

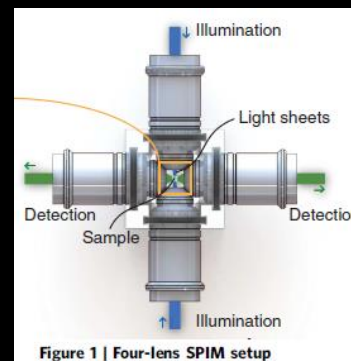

Figure 1 | Four-lens SPIM setup

Jan Huiskens
Dresden

H2B-mCherry

crestin::GFP

merge

00:00:00



Pulgar, Keller, Concha, unpublished

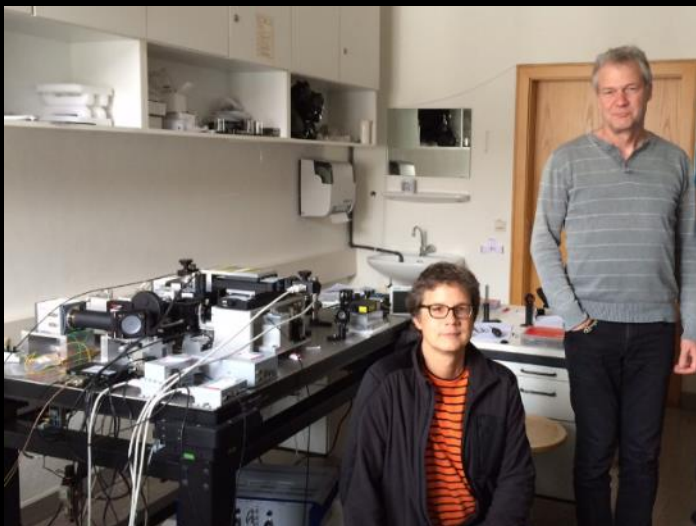

BIOMEDICAL NEUROSCIENCE INSTITUTE



BNI en la vanguardia de la microscopia

Armar microscopios de alta resolución temporal permitirá la creación de nuevas capacidades profesionales y tecnologías en nuestro país

¿Qué hay de la conectividad a gran escala en alta resolución?

Si no puede mejorar su óptica, amplíe la muestra.

La Microscopía de Expansión puede ampliar el cerebro del pez cebra por factor 4.

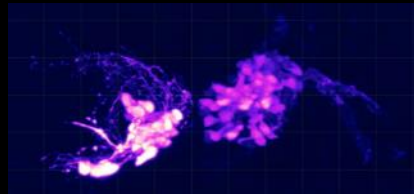

Juan Eduardo Rodríguez
Kubitscheck-Lab
Bonn University



Karina Palma
Leo/SCIAN
U-Chile

¿Qué hay de la conectividad a gran escala en alta resolución?

Si no puede mejorar su óptica, amplíe la muestra.

La Microscopía de Expansión puede ampliar el cerebro del pez cebra por factor 4.

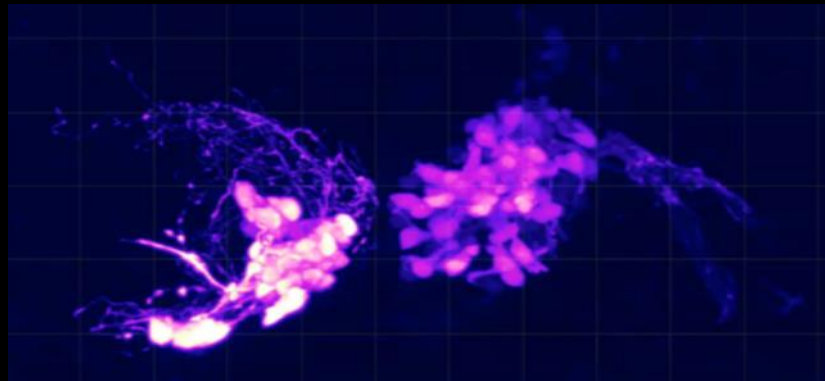

Juan Eduardo Rodríguez
Kubitscheck-Lab
Bonn University



Karina Palma
Leo/SCIAN
U-Chile

¿Qué hay de la conectividad a gran escala en alta resolución?

Si no puede mejorar su óptica, amplíe la muestra.

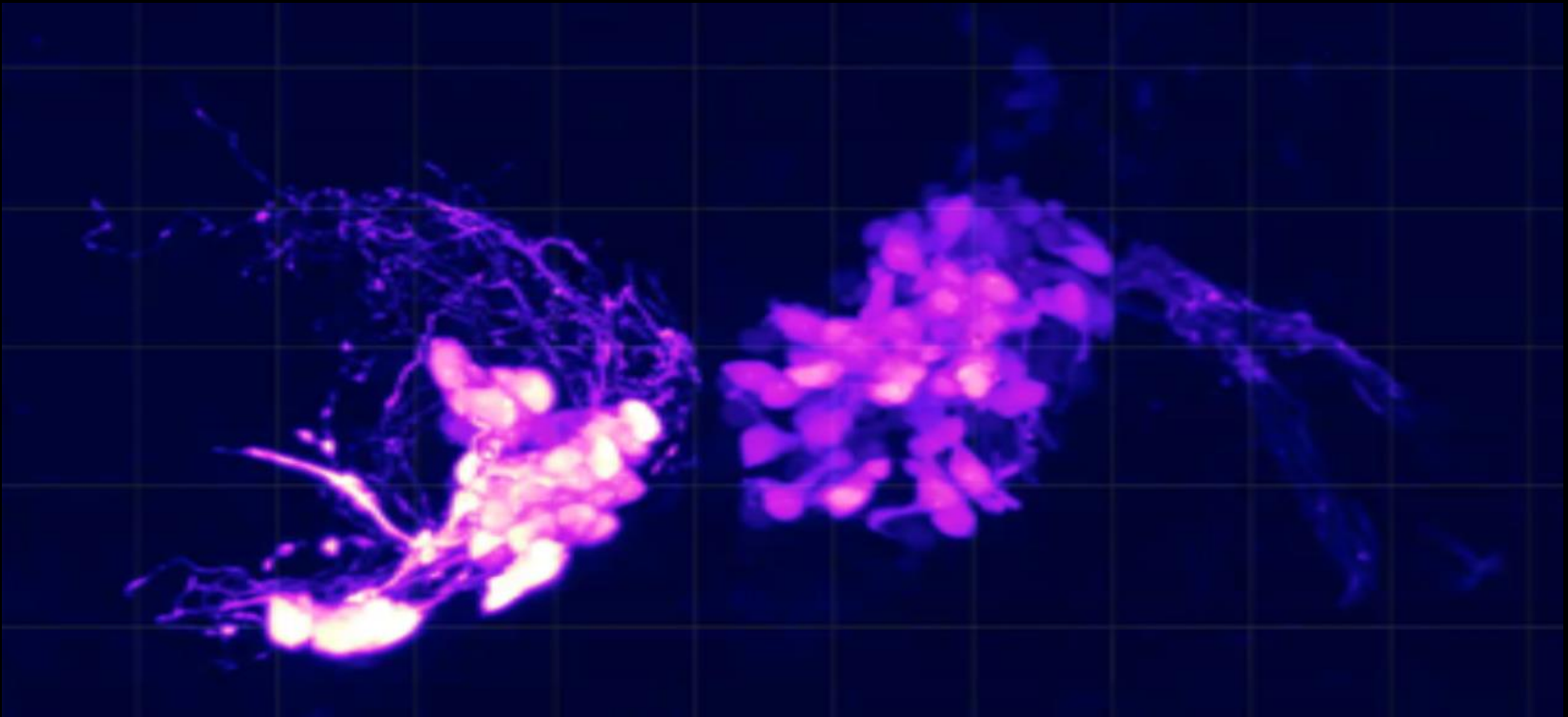



Video of a 3D view comprising 1687 slices. Volume size 1133 x 954 x 954 μm^3 (~113 GB)

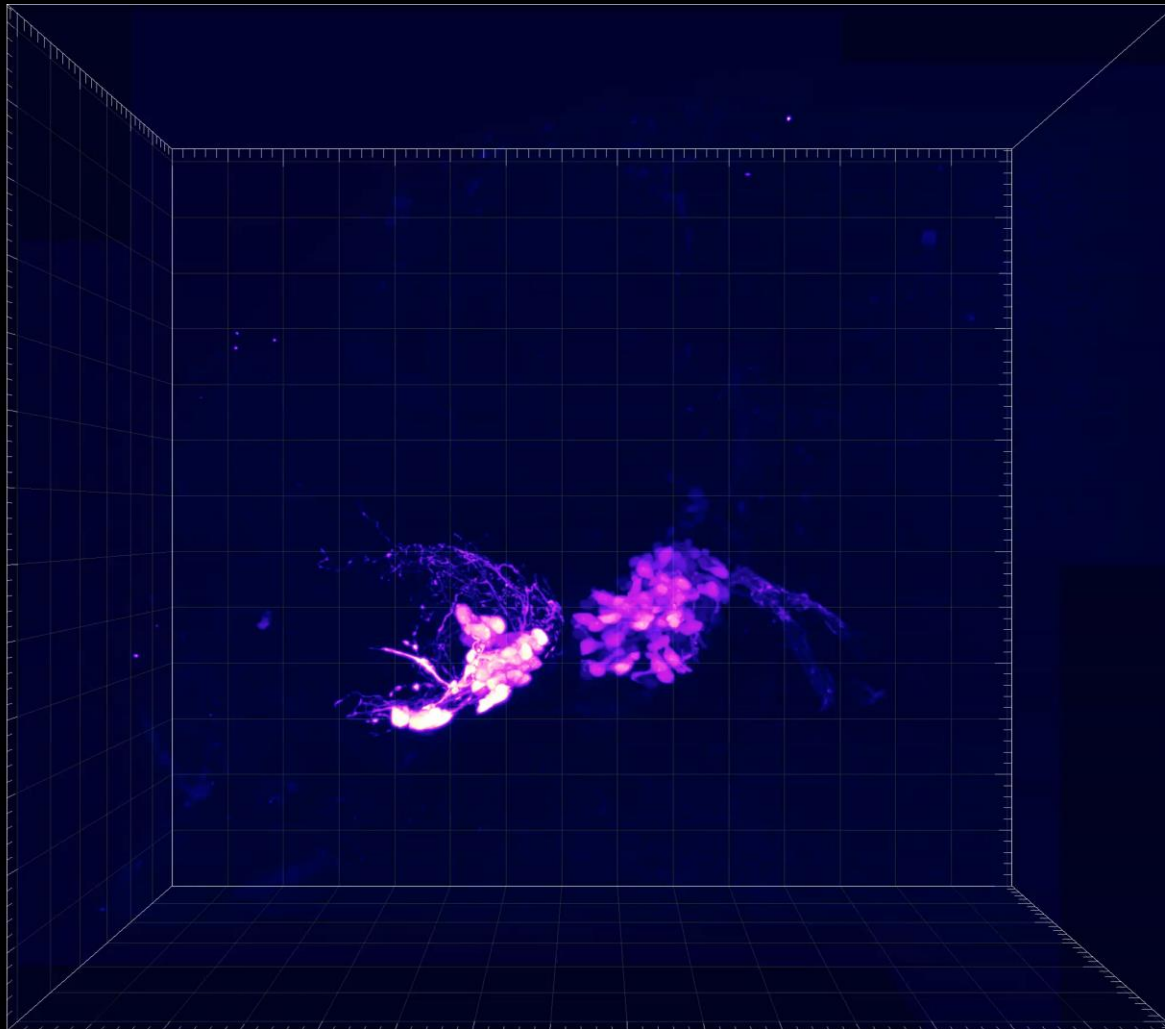

Video of a 3D view comprising 1687 slices. Volume size 1133 x 954 x 954 μm^3 (~113 GB)

Confocal

ExM + LSM

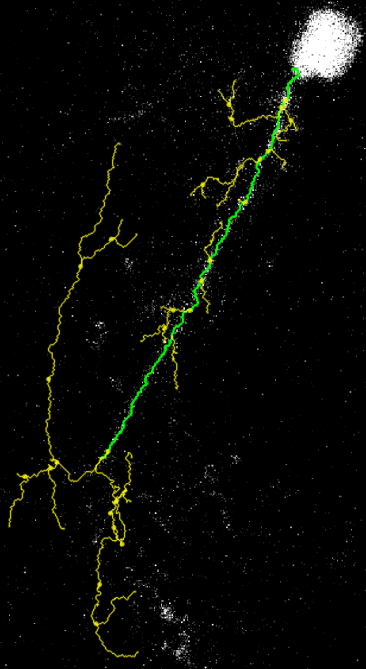

||

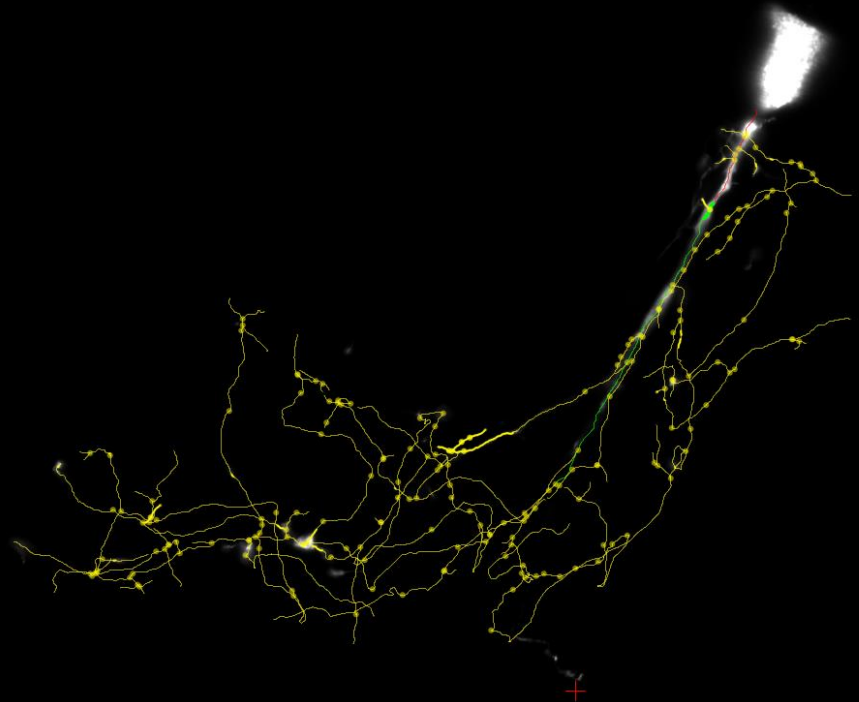

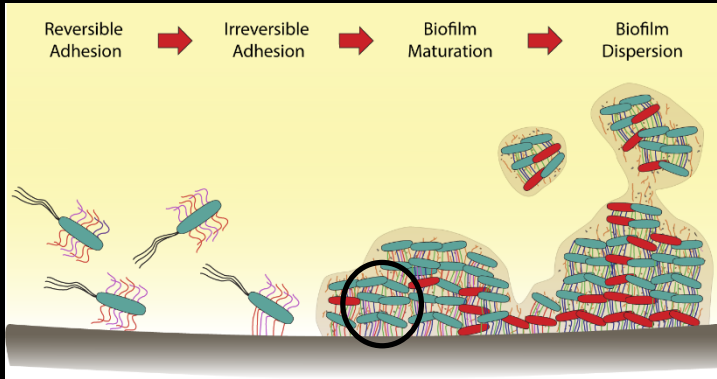

Dante Castagnini,
SCIAN-Lab, Bioquímico



MSc(c) Nicole Canales,
T. Médico, SCIAN,
Microbiología

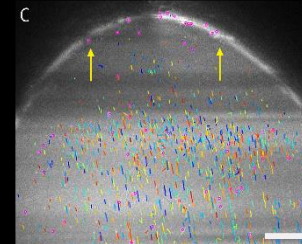
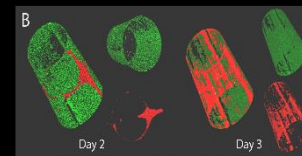
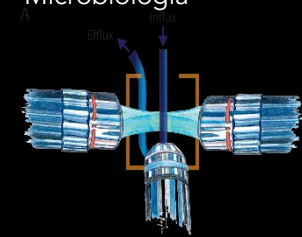
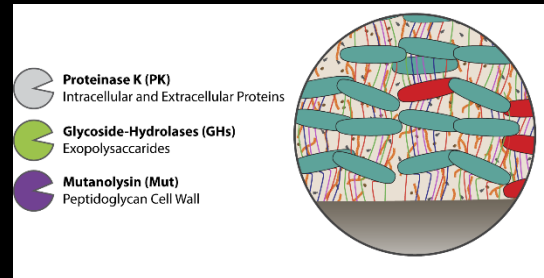
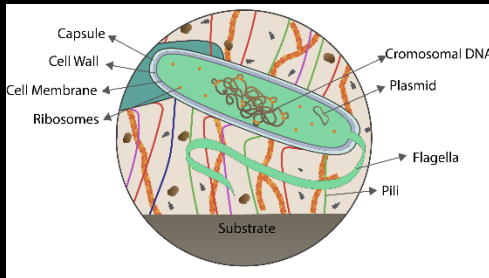

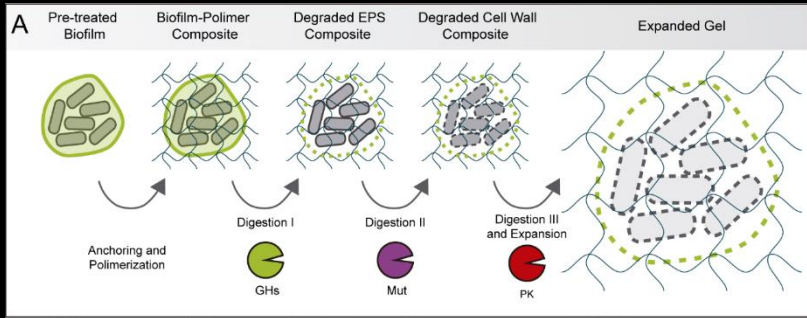

Dante Castagnini,
SCIAN-Lab, Bioquímico

